

SECTION C-C

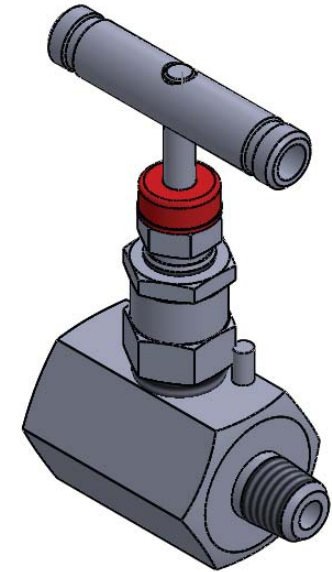

ITEM NO.	PART NUMBER	DESCRIPTION	QTY.
1	BODY	ASTM A 479-316	1
2	GLAND BODY	ASTM A 479-316	1
3	RETAINER	ASTM A 479-304	1
4	SPINDLE	ASTM A 479-316	1
5	PACKING	PEEK	2
6	PACKING	PEEK	1
7	WASHER	ASTM A 479-316	1
8	LOCK NUT	ASTM A 479-316	1
9	GRUB SCREW	SS	1
10	HANDLE	GRAFOIL	1
11	DUST CAP	SS316	1
12	DOWEL PIN	SS	1
13	NON ROTATING BALL TIP	SS440C	1

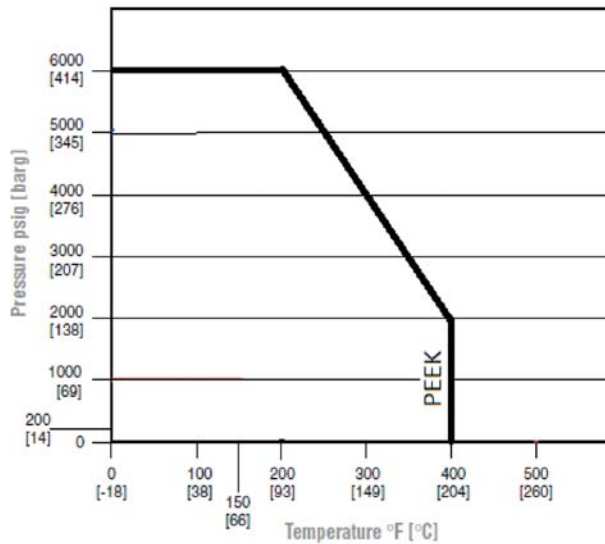

NOTES:-

- ALL DIMENSIONS ARE IN MM. UNLESS SPECIFIED.
- UNSPECIFIED GEN TOL. : ±0.5 MM MAX.
- UNSPECIFIED GEN ANG. TOL. : ±0.1° MAX.
- UNSPECIFIED ASLY. TOL. : ±2MM MAX.
- UNSPECIFIED TOL. FOR FORGING : ±2 MM.(IF APPLICABLE)
- MAX. WORKING PRESSURE : 10000 PSI

REV.	DESCRIPTION	DRN	CHD	APPD	DATE

TITLE:- 1/4" NPTM X 1/4" NPTF HB SERIES NEEDLE VALVE

DRN.	PS	SCALE - N.T.S	REV.	00
CHD.	SS	DATE - 23.03.18	PROJ.	
APPD.	DM	DRG.NO.- PNV-H-S-04-MF-HP-SG		



PANAM ENGINEERS LTD
GUJARAT - INDIA

SHEET
1
OF
1