

ITEM NO.	DESCRIPTION	MATERIAL	QTY.
1	BODY	ASTM A 479-316	1
2	GLAND BODY	ASTM A 479-316	2
3	RETAINER	ASTM A 479-316	2
4	PACKING	DELTRIN	2
5	PACKING	TEFLON	4
6	WASHER	ASTM A 479-316	2
7	NONROTATING BALL TIP	SS440C	2
8	DOWEL PIN	SS	2
9	LOCK NUT	ASTM A 479-316	2
10	WASHER	ASTM A 479-316	2
11	GRUB SCREW	SS	2
12	SPINDLE	ASTM A 479-316	2
13	DUST CAP	PLASTIC	2
14	HANDLE	SS	2

SCHEMATIC

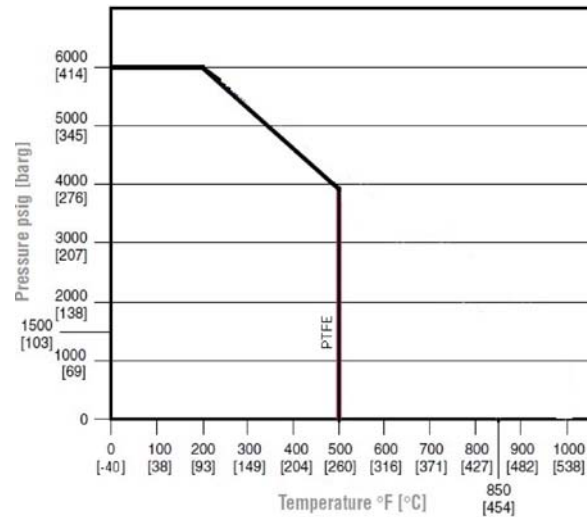
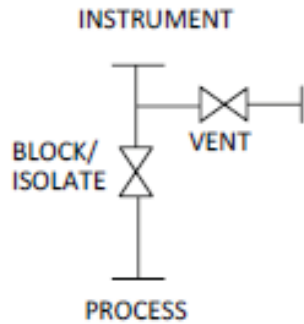

NOTES:-

1. ALL DIMENSIONS ARE IN MM. UNLESS SPECIFIED.
2. UNSPECIFIED GEN TOL. : ±0.5 MM MAX.
3. UNSPECIFIED GEN ANG. TOL. : ±0.1° MAX.
4. UNSPECIFIED ASLY. TOL. : ±2MM MAX.
5. UNSPECIFIED TOL. FOR FORGING : ±2 MM.(IF APPLICABLE)

REV.	DESCRIPTION	DRN	CHD	APPD	DATE

TITLE:- 2WAY MANIFOLD PIPE TO PIPE , 1/2" NPTF X 1/2"NPTF,6000 PSI

DRN.	PS	SCALE - N.T.S	REV.	00
CHD.	SS	DATE - 23.03.18	PROJ.	
APPD.	DM	DRG.NO.- 2VM-SS-8-R-SG		



PANAM ENGINEERS LTD
GUJARAT - INDIA

SHEET
1
OF
1