

BLEED NEEDLE VALVE

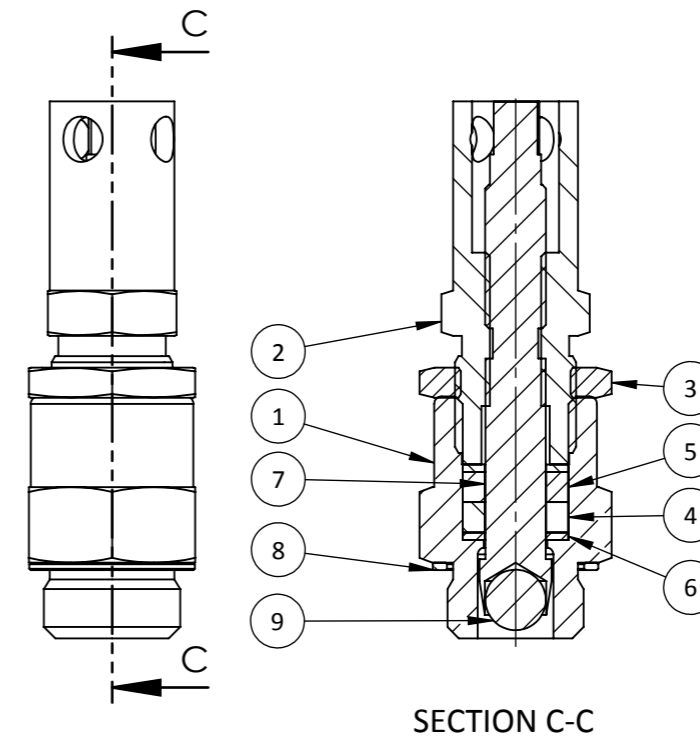
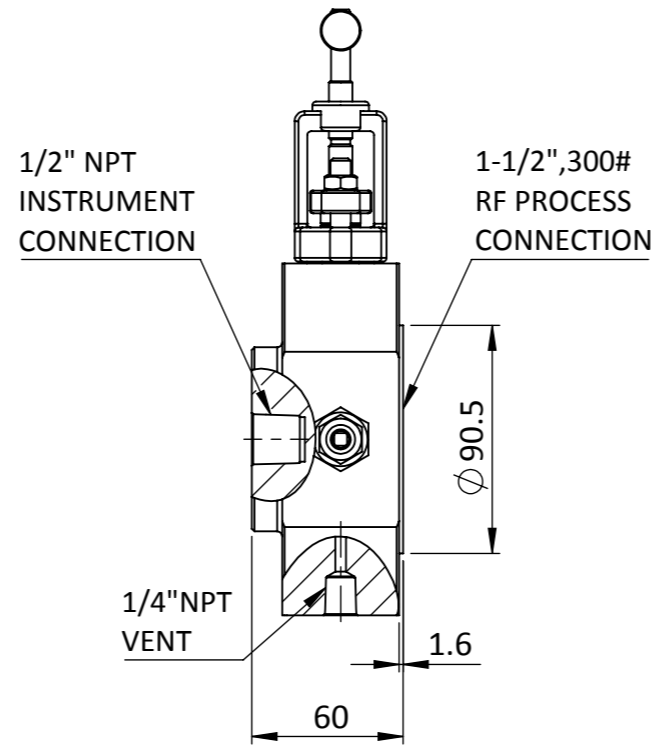
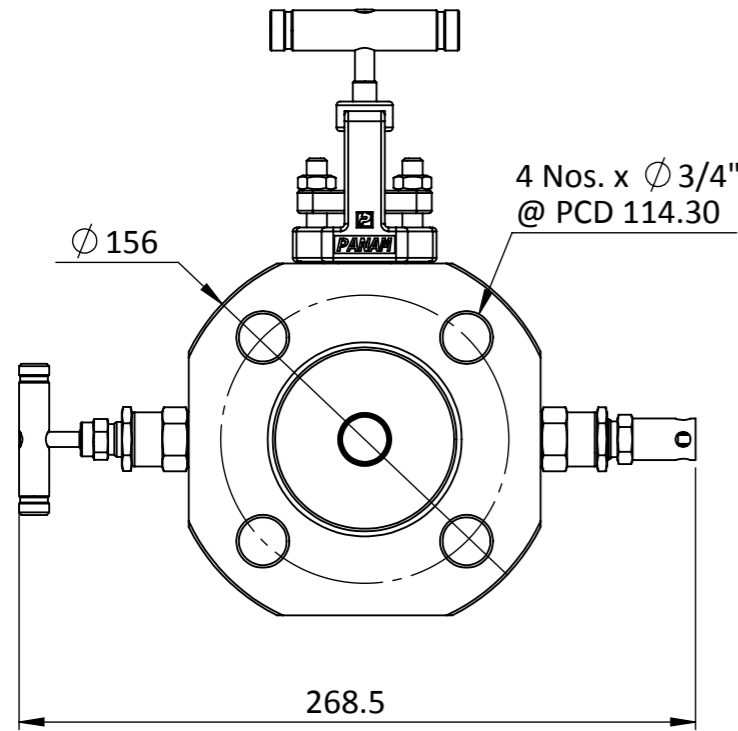

ITEM NO.	PART NUMBER	DESCRIPTION	QTY.
1	GLAND BODY	ASTM A 479-316	1
2	SCREWED RETAINER	ASTM A 479-316	1
3	LOCKING NUT	ASTM A 479-316	1
4	PACKING 1	PEEK	1
5	PACKING 2	ASTM A 479-316	1
6	WASHER	PEEK	2
7	SPINDLE	ASTM A 479-316	1
8	WASHER	ASTM A 479-316	1
9	BALL TIP	SS440C	1

ITEM NO.	PART NAME	MATERIAL	QTY
01	BODY	ASTM A 182-F316	1

BLEED VALVE

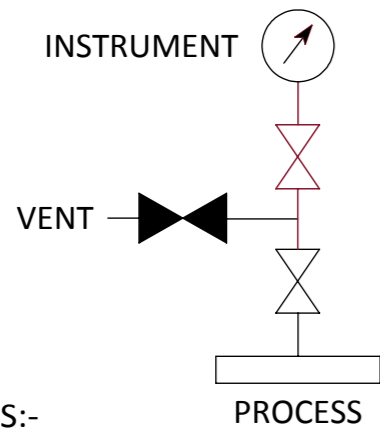
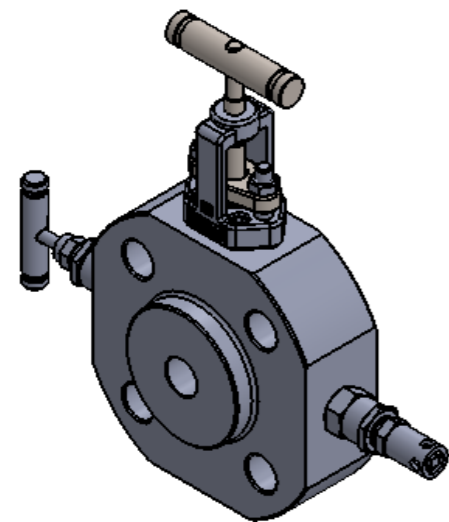

NOTES:-

1. ALL DIMENSIONS ARE IN MM. UNLESS SPECIFIED.
2. UNSPECIFIED GEN TOL. : ±0.1 MM MAX.
3. UNSPECIFIED GEN ANG. TOL. : ±0.1 ° MAX.
3. UNSPECIFIED ASLY. TOL. : ±2MM MAX.
4. UNSPECIFIED TOL. FOR FORGING : ±2 MM.(IF APPLICABLE)

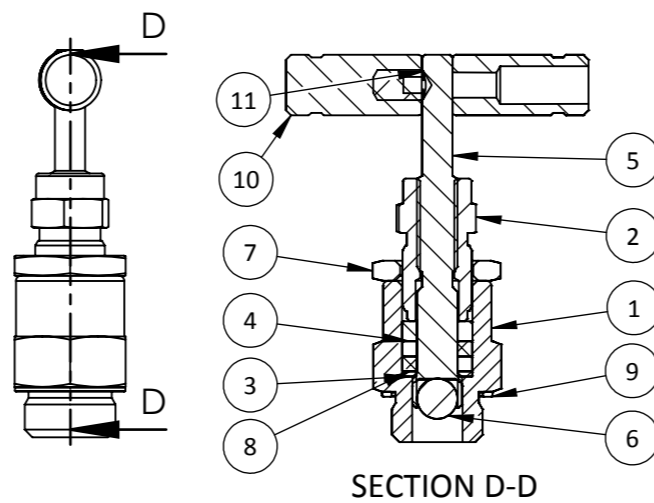

ITEM NO.	PART NUMBER	DESCRIPTION	QTY.
1	GLAND BODY	ASTM A 182-F316	1
2	RETAINER	ASTM A 479-316	1
3	PACKING	DELTRIN	1
4	WASHER	ASTM A 479-316	1
5	SPINDLE	ASTM A 479-316	1
6	BALL TIP	SS440C	1
7	LOCK NUT	DELTRIN	1
8	PACKING	PEEK	2
9	WASHER	ASTM A 479-316	1
10	HANDLE	ASTM A 479-316	1
11	GRUB SCREW	SS	1

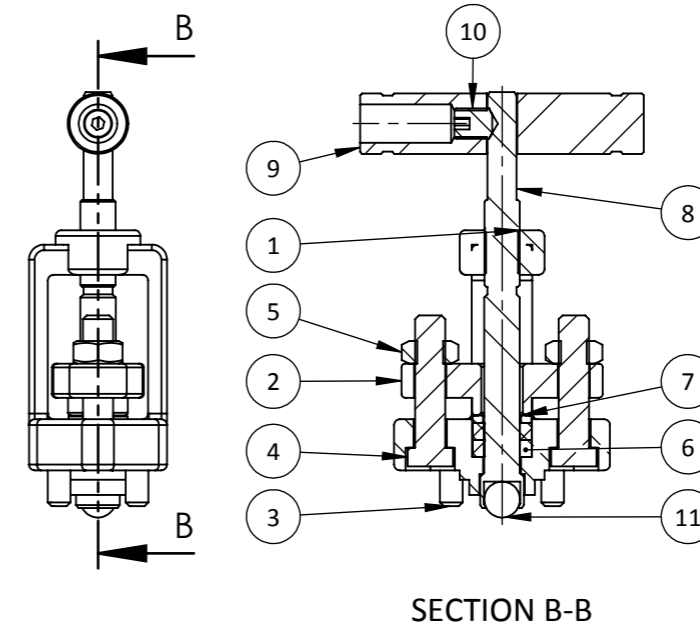

ISOLATION VALVE

ITEM NO.	PART NUMBER	DESCRIPTION	QTY.
1	BONNET	ASTM A 351 CF8M	1
2	GLAND BODY	ASTM A 351 CF8M	1
3	ALLEN BOLT	SS	4
4	HEX BOLT	ASTM A 193 GR B8M	2
5	HEX NUT	ASTM A 193 GR B8	2
6	PACKING	PTFE	2
7	WASHER	ASTM A479-316	1
8	SPINDLE	ASTM A 479-316	1
9	HANDLE	SS	1
10	M8 GRUB SCREW	SS	1
11	BALL TIP	SS440C	1

TITLE:- 1-1/2" , 300# CLASS RF 1/2"NPT PROCESS CONNECTION X 1/4"NPT BLEED CONNECTION

DRN.	PS	SCALE - N.T.S	REV.	00
CHD.	SS	DATE - 25.08.17	PROJ.	
APPD.	DM	DRG.NO.- PDBB-OSY-SS-01-40-300-RF-8NF-4N-ANTI		



PANAM ENGINEERS LTD
GUJARAT - INDIA

SHEET
1
OF
1

REV.	DESCRIPTION	DRN	CHD	APPD	DATE