

Gauge Root Valves



www.panamengineers.com

Gauge Root Valves

PANAM Gauge Root Valves are used for safe installation in pressure switches, gauges and differential pressure transmitters, suitable for Block and Bleed assemblies to test pressure source required in sampling line or purg valve.

Features:- 316 S.S. Construction for corrosion resistance. Nonrotating vee or ball tip. Extended body for insulation clearance. Scheduled 160 or heavier pipe valve inlet for strength. Optional graphoil packing available for high temperatures with all ball / vee tip design which forms a bearing joint with the stem which eliminates rotation between ball or vee tip & seat at closure, This prevents scoring and galling on the valve seat and ensures long life in repetitive shut off service.

Material of Construction

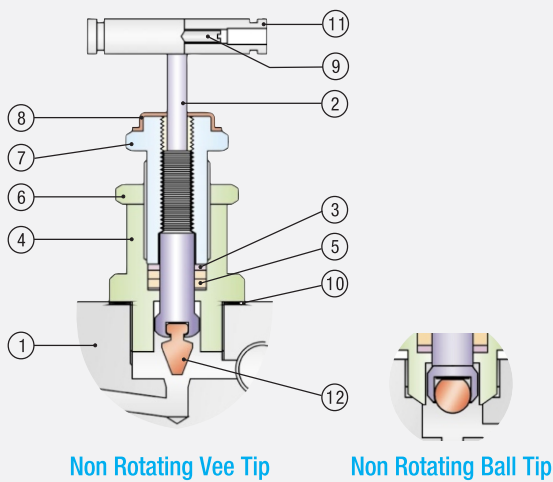

Sr. No.	Part Name	Qty.	Material
1	Body	1	A479-316 S.S. / A-105
2	Stem	1	A479-316 S.S. / A-105
3	Spacer	2	A479-316 S.S. / A-105
4	Gland Body	1	A479-316 S.S. / A-105
5	Gland Packing	2	Teflon / Graphoil
6	Gland Lock Nut	1	A479-316 S.S. / A-105
7	Gland Retainer	1	A479-316 S.S. / A-105
8	Dust Cap	1	Plastic / LD
9	Grub Screw	1	Steel Plated
10	Washer	1	A479-316 S.S. / A-105
11	Handle	1	Stainless Steel
12	Vee / Ball Tip	1	A 564-630

Dimensions

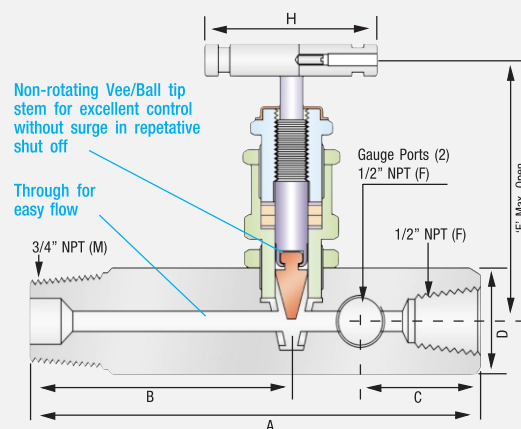
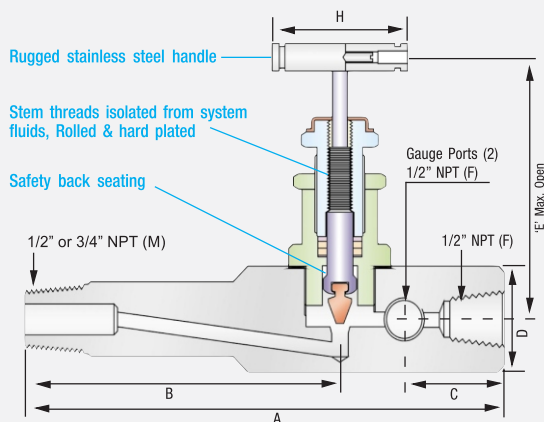

Body	Orifice mm	Connecting Size		Dimensions					
		Inlet	Outlet	A	B	C	D	E	H
Short	5	1/2" NPT	1/2" NPT	137	76	38	32 SQ.	90	64
Lagging Extension		3/4" NPT	1/2" NPT	184	123	38	32 SQ.	90	64

MAT.	SEAT	TEMP. RATING	PR. RATING @ 100° F (38° C)
SS 316	V-Stem Rising Plug	-65° F to 450° F (-54° F to 232° C)	6000 PSI (41,300 Kpa)

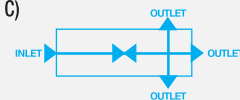

Testing

Each valve is hydrostatically tested in accordance with MSS-SP-99. This procedure includes testing of the body cavity. Hydrostatic test is performed with pure water or other liquids of similar or lower viscosity at 1.5 times and seat leakage test at 1.1 times of the maximum working pressure. Each valve is also tested with Nitrogen Gas at 1000 psi for seat, seal and shell leakage. Other tests like Vibration, Temperature, Helium are available upon request.

PANAM ENGINEERS LTD.

An ISO 9001:2008 Company

203, Jaisingh Business Center, Parsiwada, Sahar Road, Andheri (East), Mumbai - 400 099. INDIA
 Tel.: +91 22 2831 5555 / 57 / 58 • Fax: +91 22 2831 5574 • email: sales@panamengineers.com / sales@panam.in
 website: www.panamengineers.com / www.panam.in