



CROSSFIRE

CHEMICAL INJECTION PUMP

Ultra-low Power Chemical Injection Pump

Installation and Operations Manual
Version 6.4

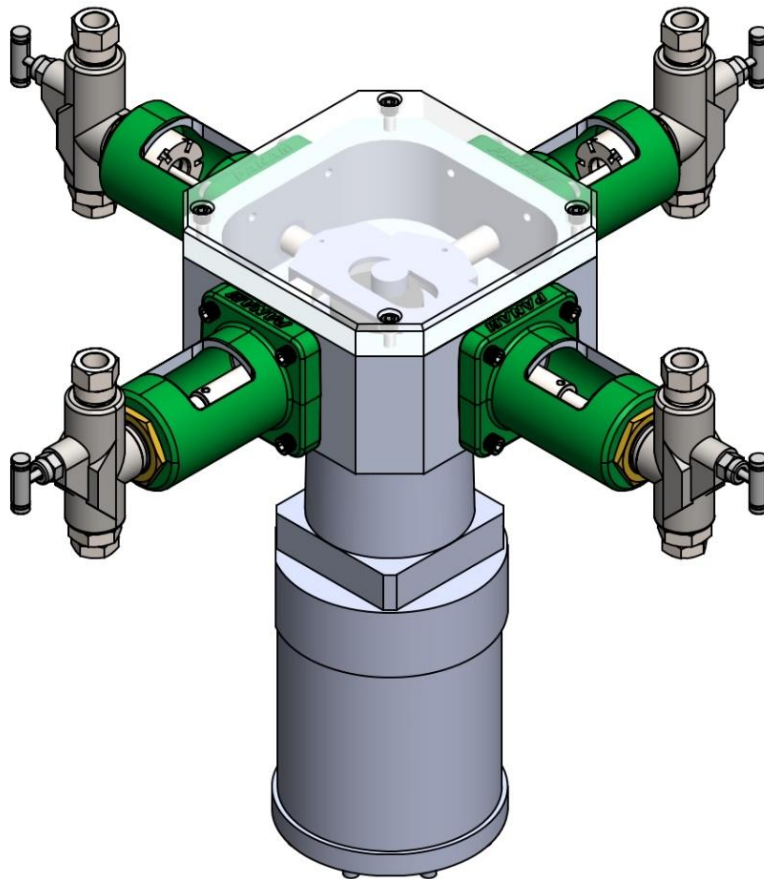

Table of Contents

CSA Requirements and Installation Requirements	4
CROSSFIRE Installation Guide	8
Optional Step: Connect the CROSSFIRE to a SCADA/RTU System	12
Optional Step: Wire in Motor soft stop switch (non-positive isolation feature)	14
<i>Soft Stop Feature – Wiring Diagram</i>	15
CROSSFIRE Pump Start Up	17
Software Installation:.....	19
Step 1: Download the Computer Interface Software	19
Optional: Mobile Application	19
Interface Guide	20
Interface Overview	20
Main menu	21
Motor Control Tab	23
Motor Control Panel	25
System Status Tab.....	26
System Setup Tab	27
System I/O Tab	30
Automation Tab.....	31
Terminal Tab.....	36
Frequently Asked Questions: Automation & MODBUS.....	38
Troubleshooting:	40
Controller Fault:.....	40
Fault Codes:	42
Pump and fluid end: Troubleshooting	43
Controller Software Connection: Troubleshooting	47
Connection Errors.....	47
COM Port Issues	48
CROSSFIRE Maintenance.....	49
Maintenance Instructions:	50
Replacement of LCO One N’ Done Packing and Plunger:.....	50
Replacement of Chevron Vee Packing and Plunger:	51
Inspection	52
Controller Firmware Upgrade:.....	53
CROSSFIRE Return and Repairs	57
Repairs.....	57
Replacement	57
Return Procedure	57

CSA Requirements and Installation Requirements

IMPORTANT SAFETY CONSIDERATIONS

WARNING

AVERTISSEMENT

EXPLOSION HAZARD - SUBSTITUTION OF COMPONENTS
MAY IMPAIR SUITABILITY FOR INSTALLATION IN HAZARDOUS LOCATIONS
RISQUE D'EXPLOSION - LA SUBSTITUTION DE COMPOSANTS
PEUT RENDRE CE MATÉRIEL INACCEPTABLE POUR LES
EMPLACEMENTS DANS DES ENDROITS DANGEREUX (CLASSE 1, DIVISION 2).

WARNING

AVERTISSEMENT

EXPLOSION HAZARD - DO NOT REPLACE COMPONENTS
UNLESS POWER HAS BEEN SWITCHED OFF OR THE AREA IS
KNOWN TO BE NON-HAZARDOUS.
RISQUE D'EXPLOSION - COUPER LE COURANT OU
S'ASSURER QUE L'EMPLACEMENT EST DÉSIGNÉ NON
DANGEREUX AVANT DE REMPLACER DES COMPOSANTS.

WARNING

AVERTISSEMENT

EXPLOSION HAZARD - DO NOT CONNECT OR DISCONNECT EQUIPMENT
UNLESS POWER HAS BEEN SWITCHED OFF OR THE AREA IS
KNOWN TO BE NON-HAZARDOUS.
RISQUE D'EXPLOSION - AVANT DE DÉBRANCHER
L'ÉQUIPEMENT, COUPER LE COURANT OU S'ASSURER
QUE L'EMPLACEMENT EST DÉSIGNÉ NON DANGEREUX

WARNING

AVERTISSEMENT

THE CONTROLLER ASSEMBLY IS FOR USE IN CLASS I, DIVISION 2, GROUPS C AND D, AND OR
NONHAZARDOUS LOCATIONS ONLY.
L'APPAREIL DU CONTRÔLEUR CONVIENT À L'UTILISATION DANS LES EMBLEMES
DE CLASSE 1, DIVISION 2, GROUPES C ET D, OU NE CONVIENT
QU'À L'UTILISATION DANS DES EMBLEMES DÉSIGNÉS NON DANGEREUX.

WARNING

AVERTISSEMENT

THE MOTOR ASSEMBLY IS FOR USE IN CLASS I, DIVISION 1, GROUPS C AND D, AND OR
NONHAZARDOUS LOCATIONS ONLY.
L'APPAREIL DU MOTEUR CONVIENT À L'UTILISATION DANS LES EMBLEMES
DE CLASSE 1, DIVISION 1, GROUPES C ET D, OU NE CONVIENT
QU'À L'UTILISATION DANS DES EMBLEMES DÉSIGNÉS NON DANGEREUX.

**AGENCY
CERTIFICATION****Controller Assembly**

(Must be placed in a Cabinet/Enclosure that provides a minimum Ingress Protection of NEMA 4/IP54)

Class 1, Division 2, Groups C and D, or nonhazardous.
Temperature Code: T4, Tamb: -40 – 60 Deg. C.
Suitable for Zone 2, IIB.

Motor Assembly

(Motor is for indoor or protected environment use only)¹

Class 1, Division 1, Groups C and D, or nonhazardous.
Temperature Code: T6, Tamb: -40 – 60 Deg. C.
Suitable for Zone 1, IIB.

Models:

Explosion Proof Motor Assembly Model LCOM-1000
Controller Model LCOC-1000-A and Model LCOC-1000-B

IMPORTANT: Conditions of Certification

- ✓ The Controller must be installed within an enclosure suitable for the environment and requiring a tool or key to open. Controller Models LCOC-1000A and LCOC-1000B are intended for use in a Pollution Degree 2 environment.
- ✓ The RS232 connector must be retained with two screws on the mating connector.
- ✓ The Ethernet RJ45 connector must be retained with its original locking tab to withstand a 15 Newton pull force once engaged.
- ✓ Model LCOM-1000 must be used together to form a Certified Brushless DC (BLDC) Motor System. No substitutions of Motor types are permitted.

Controller

The controller input voltage rating is: 24 VDC. The Battery power supply must be capable of supplying 24 VDC to ensure reliable operation and motor start-up. For average current draw based on application, and help with solar sizing, please contact LCO directly. Average current draw on most applications is significantly less than 1 A, however the rated maximum current draw for the controller is 9.6A.

The Controller must be protected by external over current protection in keeping with CEC and NEC practices supplied at the time of installation.

****NOTE**:** It must be noted that the controller is certified as C1D2, and the equipment is for C1D1. To maintain CSA approvals our controller is circuit protected with an on-board fast burn precision 9.9A fuse. It is imperative that any installation have a fast burn fuse and be rated for LESS than 9.9A. LCO's suggestion is to use 8A fast blow fuse rated for your application installation needs.

¹ Note: Protected environment means the motor must be under a shelter and off the ground to protect the motor from moisture (such as rain, snow, ice etc.)

EXTERNAL CONNECTORS

The controller features several external connectors. These are labelled as follows:

- Power In: connectors are used to connect the 24VDC power supply.
- To Motor: connectors are used for Phase A, Phase B and Phase C of BLDC. These connections are not phase sensitive.

Use only Copper (Cu) Conductors on Supply and Motor Load Terminal Blocks

“TIGHTEN TO 10.54 pound-inches (1.2 N•m)”. Or Equivalent

It is a CSA requirement to use #10 straight or ring lugs with 10 AWG wiring, when connecting to the Power and Motor connectors. The Controller data connectors can accept 20 to 24 AWG stranded wire.

All wiring and connections must be in line with accepted wiring practices as outlined by the Canadian Electrical Code (Canada) and the National Electrical Code (USA) and installed by qualified personnel only. (Use copper conductors only)

There are two patterns of mounting holes on the Controller unit. The four corner mounting positions are for a direct fastening to the enclosure using # 6 screws. The two patterns of 3 holes are for DIN Rail mounting brackets. Installer must supply screws and brackets as applicable.





It is required that a cutoff switch is installed on the +24 VDC power rail, between the controller and supply. This allows for safe servicing of the controller, and eliminates any arcing caused by manual connection or disconnection of the supply rail. Failure to do so may result in personal injury or damage to the controller.

Motor

Accurate mechanical lineup is essential for successful operation. Mechanical vibration and roughness while running the motor may be an indication of poor alignment. It is recommended that the lineup be checked when installed.

For direct coupled applications, use flexible couplings when possible. Use of a sealed fitting at the motor wiring entrance point is required with a minimum of 5 full thread engagement to maintain the Class I, Division 1 rating of the motor when installed in a Hazardous Area.

The three Phase conductors and the Earth ground must be terminated in an approved Class I, Division 1 junction box. The green Earth lead must be grounded to the ground screw in the junction box.

WARNING: Motor, Control and Grounding must be in accordance with the Canada - Canadian Electrical Code and/or USA – National Electrical Code and consistent with Local requirements and practices. Use Ground lug on exterior of Motor enclosure and Ground lead provided to ensure proper Grounding of the Motor.

See below for Safe Operating Area Curves (SOAC) for the Motor

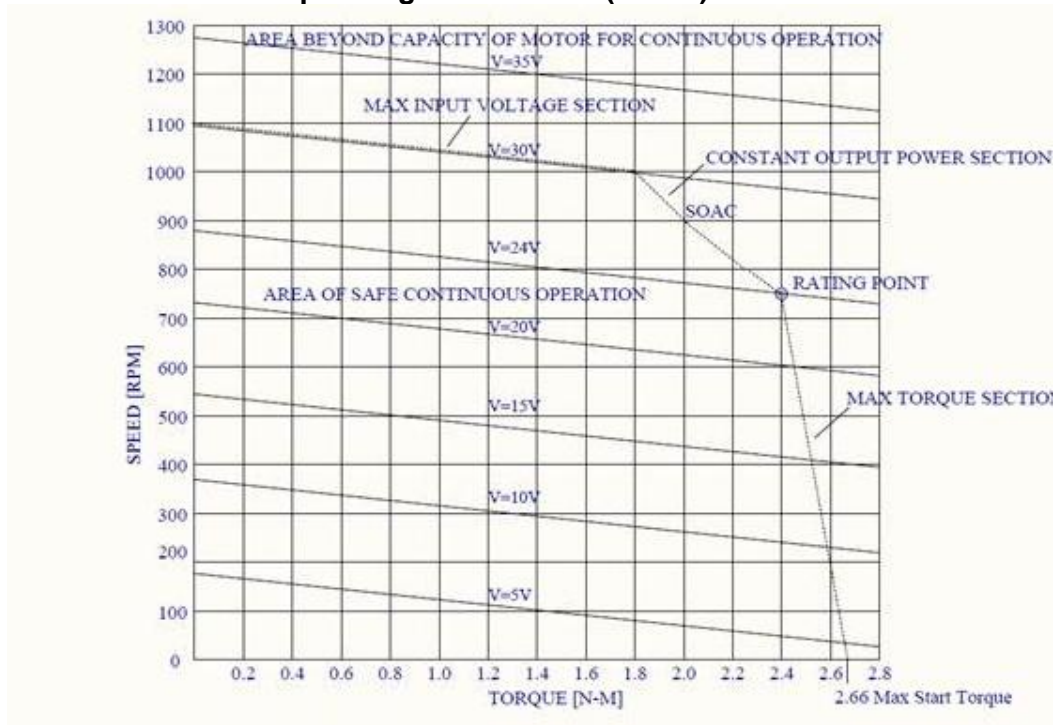

Figure: Safe Operating Area Curves (SOAC)

CROSSFIRE Installation Guide

Step 1: Open Boxes

- Confirm the following parts are present
 - Pump Box:
 - Assembled Pump
 - Yoke covers
 - Controller Box:
 - LCOC-1000-A (advanced) or LCOC-1000-B (basic)
 - Additional accessories ordered (mounting bracket etc.)
- Check to ensure no parts were damaged during shipment
 - Contact the shipment carrier and file a claim if any damage has been identified
 - If replacement parts are required, please contact supplier
- Familiarize yourself with all parts and pieces

Step 2: Mount the pump

- Find a desired location for installation
 - A location that can accommodate pump dimensions (22" L x 22" W x 17" H)
 - Minimize elevation to exploit head pressure created by the chemical tank
 - This will assist in priming the inlet line
- Mount the mounting bracket and pump within the bracket
 - The mounting bracket is designed to bolt down to the pattern of a 5100 series pump.
 - Bolt the two bracket pieces onto the existing 5100 pattern
 - Set the *CROSSFIRE* pump on top of the bracket
 - Attach the four bolts through the bracket and into the base of the motor enclosure
 - Fasten until tight

Note: The bracket can be drilled to accommodate other bolt pattern configurations. Alternatively, the pump can be free standing on the bracket; it can be attached to the bracket but not bolted down in a drip tray if preferred.

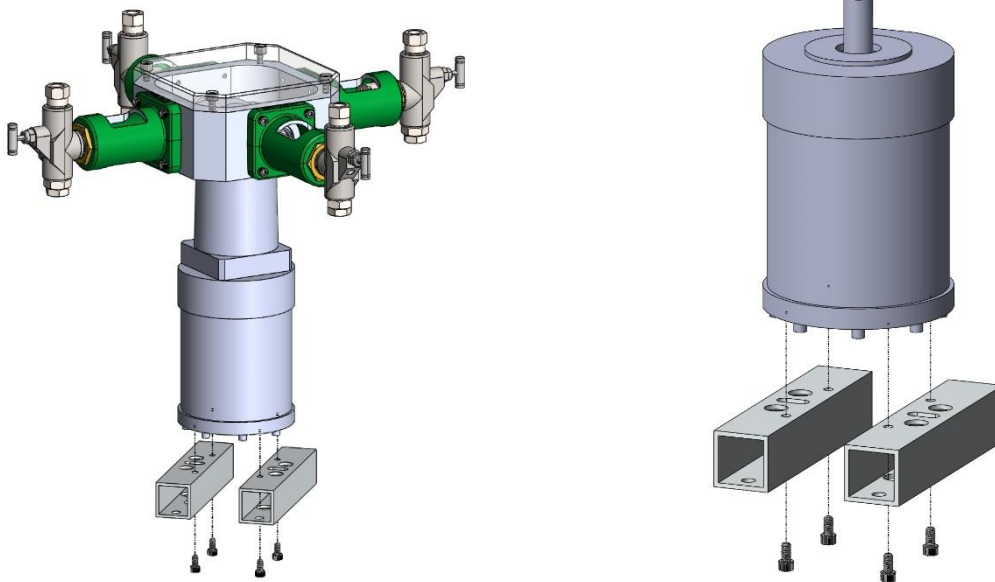

Step 3: Install the Smart Controller

- Mount the Controller in a NEMA 4 Enclosure
- **Install 8A Fuse**
- Connect the controller to a 24 VDC power supply
 - Connect the two conductors, **10-gauge tech cables** with appropriate environmental and classification seals to the controller
 - Ensure the cables are no longer than **60ft**
- Attach the three conductor cables from the motor to the controller. The green ground wire can be terminated at any ground.
- The conductor cables must be terminated in a Class 1, Division 1 junction box at the motor.



Conductor Cable Termination in Junction Box



Conductor Cable Termination on Controller

- Use an appropriate terminal block to terminate conductor cables in the junction box such as ADELS contact 3-pole terminal block (photo below)
- Scan the QR Code to the right for more information on the recommended terminal block and its technical specifications
- The three conductor cables will be terminated in the controller at termination points marked phase A, phase B, and phase C. Although the wires are not required to be in a particular order for the pump to function, to maintain consistency please attach the **red wire to PH A**, the **black wire to PH B**, and the **yellow wire to PH C**.
- Cables must be **gauge 10** and a **maximum length of 60 ft** as per the [critical installation guidelines](#).



Warning: If the resistance in the gauge 10 wires does not meet AWG standards, the distance must be reduced proportionately.

Note: All conductor cables must be attached with proper end ferrule connectors and clamped down with the appropriate tools. Confirm all screw terminals are tightened down to avoid any electrical connection issues. Similarly, if two wires must be spliced together, please use a proper splicer connector, clamp down sufficiently, and **do not use electrician twist caps (marrettes)**. **Only use terminal blocks or set screws.**

Note: **Wiring instructions are per device. Multiple CROSSFIRE units cannot be wired off a single cable run. Any deviation can affect CROSSFIRE performance. Please consult LCO Technologies directly for assistance prior to deviation if required.**

Step 4: Check Fluid Ends

- Reference the graphics below and ensure the correct number of threads are showing between the brass lock nut and the fluid end body
 - o Depending on the yoke and packing style, this will vary
 - o If using an **LCO One N' Done packing** (part number series PFE-SS-00-1ND-XF), ensure the thread count is **showing 0-1 threads** regardless of yoke style and confirm setup with manual rotation



Warning: *If the incorrect number of threads are showing, the plunger may bottom out or cause accelerated wear on the packing and inaccurate chemical injection. If the plunger bottoms out, this may cause damage to the center cam wheel and motor, which may cause chemical leaks over time. If the fluid end is too far out from the platform, the plunger will come out of the lip seal, resulting in a leaky fluid end and damage to the packing. Both scenarios are not covered under warranty so please ensure the fluid end is set up correctly and confirm setup by completing a manual rotation (described on next page).*

**Original Yoke
Set with 6-7 Threads**



**Original Yoke w Spacer
Set with 1-2 Threads**



**2nd Edition Yoke
Set with 0-1 Threads**



**3rd Edition Yoke
Set with 0-1 Threads**



*Threads between
fluid end body
and brass lock nut
(0-1 threads)*

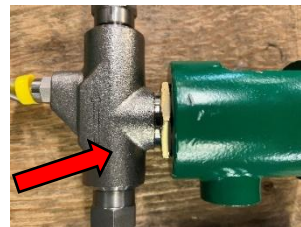

- If the fluid end installed has a standard chevron vee packing (part number series PFE-SS-00-XX), check that the packing gland adjustment nut is snug but not over tightened.
- If using a LCO One N' Done packing (part number series PFE-SS-00-1ND-XF) tighten the packing gland adjustment nut until it stops. These packings are non-adjustable so they will not need to be adjusted after initial installation.

Step 5: Manual Rotation Check

- Complete a manual rotation fluid end check to ensure the fluid ends are properly installed
- Remove the clear acrylic top cover from the pump
- Insert an Allen key into the bolt in the center motor shaft and manually spin the motor (figure A)
 - The motor should spin 360 degrees with no resistance
 - If there is resistance that cannot be rotated past, a fluid end is bottoming out on the plunger
 - In such event, manually spin the fluid end out and off the yoke, one full turn at a time, until you can rotate past the fluid end
- Then, align the apex of the cam in line with the fluid end of interest (figure B)
 - Turn the fluid end in (further onto the green yoke) until the plunger bottoms out on the inside of the fluid end
 - Back the fluid end off, just until the arrow on the side of the fluid end body is pointing up (less than one full turn) (figure C)
 - Tighten brass lock nut to secure position
 - Repeat this process on all fluid ends
- Re-check and complete a full 360-degree rotation

For more information, and a visual representation of the manual rotation, please visit www.lcotechnologies.com/resources.html and watch the YouTube Video called “**Video Tutorial Manual Fluid End Check**” or call LCO directly for more assistance



Warning: The initial 360-degree manual rotation will only indicate if a fluid end is installed too close to the platform (plunger bottoming out). It **will not indicate** if a fluid end is **installed too far out** from the platform, which is equally important. If a fluid end is installed too far out, it can damage the packing and cause chemical leaks. Reference the graphic on page 9 for recommended thread count and check all fluid ends as described above, even if the initial 360 rotation check passes. If the fluid ends are not properly installed, this will cause damage to the pump and may lead to extreme wear and tear.

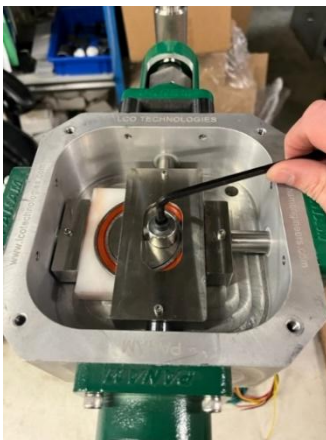

Figure A: Manually rotate 360 degrees with allen key

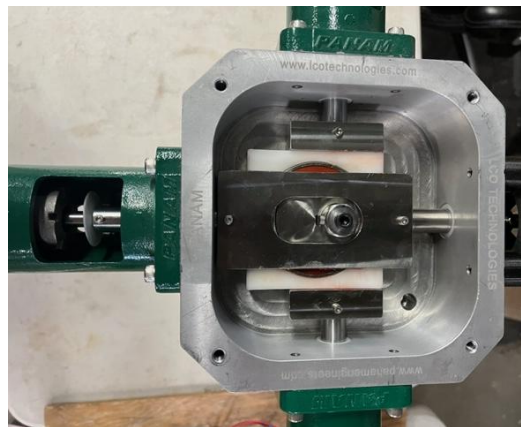

Figure B: Align apex of cam with fluid end of interest (marked with yellow arrow)



Figure C: Fluid end arrow pointing up

Step 6: Tube Fluid Ends

- The fluid ends on the *CROSSFIRE* are a 5100 series equivalent
- The fluid ends have a ¼" Female NPT connection on the inlet and outlet
 - o The arrow on the side of the fluid end body indicates fluid flow direction
- Tube the fluid ends inlets and outlets appropriately
- **Recommendation:** Use a ¾" or 1" line from the chemical tank to the pump in installations where there is more than one fluid end pumping the same chemical. A ½" line does not keep up with the suction required for multiple fluid ends.
- Overpressure protection must be used in conjunction with our pump
 - o We recommend using a Panam Relief Valve (PRV-04-SS) with an established set pressure that is no greater than the maximum allowable working pressure (MAWP) of the system. Only one relief valve is required if all fluid ends are going to a single injection point. Multiple relief valves are required for multiple injection points (one relief valve per injection point).
- **Recommendation:** Use a filter on the pump inlet to prevent foreign particles entering the fluid ends during chemical injection and damaging pump components. If injecting a chemical mixture of Methanol or Silicone based corrosion inhibitor, this is essential. Review troubleshooting section on page 45 for more information.

Optional Step: Connect the *CROSSFIRE* to a SCADA/RTU System**Connection over Serial RS485 Terminal:**

- Connect three 20 Gauge wires to the RS485 terminal blocks on the *CROSSFIRE* controller
 - o RS485+, RS485-, and RS 485 GROUND
- Connect the wires to the SCADA/RTU system
- Cable requirements: Max **300ft** long, **Gauge 20**, single stranded, twisted and ground shielded
 - o **Recommendation:** Add a 120 ohm termination resistor at the RTU or enable resistor on RTU unit if available. This will reduce noise in signal and will help prevent communication problems especially in installations with long cable runs (150-300ft).
- Install a two-position selector switch on the outside of the NEMA 4 enclosure to ensure when an Operator is on-site completing maintenance, that the pump can be manually switched from remote control mode to local control mode for safety. All MODBUS registers can be monitored remotely when the switch is on remote control mode.
 - o Wire the switch to the Digital Input DI1+ terminal block on the controller such that 24 VDC will be on DI1+ when remote position is selected and 0 VDC for the local positioner
- Download and connect to the *CROSSFIRE* computer software as per the download and operations instructions on page 18
 - o Log in as "Technician" for access to all tabs
 - o Go to "*System Setup*" panel (picture on page 26)
 - Select "*RS485*" from the dropdown menu in MODBUS Configuration panel
 - Press "*Save*" button
 - Set your Slave ID and Baud Rate
 - Press "*Save*" button
 - o Go to "*Automation*" Tab (picture on page 30)
 - Select "*local remote switch control*" from the drop-down menu to enable the two-position selector switch
 - Press "*Save*" button
 - Label position one and two on the outside of the panel to "local" and "remote"
- Cycle power on the controller to confirm MODBUS RS485 is running and communicating

Connection over Ethernet:

- Only available on **Advanced Controllers (LCOC-1000-A) with V38 Firmware or later**
- Connect a standard Ethernet CAT5 cable to the Ethernet port on the controller
- Connect the other end of the CAT5 cable to the network or router on-site
 - CAT5 Cable requirements: Max 350ft length
- Install a two-position selector switch on the outside of the NEMA 4 enclosure to ensure when an Operator is on-site completing maintenance, that the pump can be manually switched from remote control mode to local control mode for safety. All MODBUS registers can be monitored remotely when the switch is on remote control mode.
 - Wire the switch to the Digital Input DI1+ terminal block on the controller such that 24 VDC will be on DI1+ when remote position is selected and 0 VDC for the local positioner
- Connect to the **CROSSFIRE** computer software as per the instructions on page 18
 - Log in as “Technician” for access to all tabs
 - Go to “**System Setup**” panel (picture on page 26)
 - Select “**Ethernet**” from the dropdown menu in MODBUS Configuration panel
 - Press “**Save**” button
 - Change **TCP port** from standard 502 if required
 - Set your **IP address**, **Subnet mask**, and **Gateway** in the **Ethernet Configuration panel**
 - Press “**Save**” button
 - Go to “**Automation**” Tab (picture on page 30)
 - Select “**local remote switch control**” from the drop-down menu to enable the two-position selector switch
 - Press “**Save**” button
 - Label position one and two on the outside of the panel to “local” and “remote”
- Cycle power on the controller to confirm MODBUS Ethernet is running and communicating



For all MODBUS register maps and assistance to set up MODBUS, please contact LCO Technologies directly at info@lco technologies.com

Note: MODBUS communications are also available over Serial RS232. This requires a special-order controller as both a firmware and hardware update are required. Contact LCO for more information and assistance in connecting. Controller will be pre-configured to RS232 MODBUS communications so there is no software configuration required. Ensure crossover from transmit terminal to receive terminal and visa versa.

Optional Step: Wire in Motor soft stop switch (non-positive isolation feature)

- If connecting over MODBUS, a C1D2 two-positioner switch may be wired to the controller for a local “Start/Stop” motor switch. This switch will allow Operators on-site to turn the motor ON or OFF with an easy switch (no laptop or Bluetooth connection required). This will not prevent MODBUS users from viewing pump parameters remotely, as the power to the controller has not been affected.
- Note: This is not a positive isolation method of stopping the motor, consider this equivalent to the “start/stop” buttons in the app and laptop software

Feature Availability and Wiring Requirements:

- Basic Controllers – All versions
 - Wire button or switch to **A13+**
- Advanced Controllers
 - With firmware version V37 or prior – Wire button or switch to **A13+**
 - With firmware version V38 or later - Wire button or switch to **DI3+**
- For assistance identifying controller version or model, please look directly on the green controller. There will be a part number label “LCOC-1000-B” for basic or “LCOC-1000-A” for advanced and a white tag on the bottom right side of the controller listing the version number (ie:190801**V35**).



Warning: The soft stop feature does not provide positive energy isolation and it should not be used for emergency shutdown. This feature provides on/off switch functionality, and it should be wired in fail-safe mode.

Installation Instructions

- Wire 24V straight to A13+ or DI3+
 - Power can come from the main power supply
 - Wire the positive end to A13+ or DI3+ and the negative end to “GND” in the Analogue I/O terminal block (any GND will be sufficient as they are a common ground)
- Install a stop button or an on/off switch to A13+ or DI3+ and ensure the switch is within arms reach of the pump or compressor
 - Install switch as per local electrical code requirements and ensure it is rated for hazardous area
- Ensure 24V is at A13+ or DI3+ so when energized, the unit will run
 - When the provided power is 0V, the unit will stop (fail safe wiring and operation)
- Connect to the LCO Technologies Software on your desktop computer or mobile app
 - Log in as “Technician”
 - Password “Automatic”
 - Go to the “system setup” tab
 - Enable the function titled “motor soft stop” by selecting “enable” from the drop-down menu
- Check that function is working. The unit should stop at 0V and run when energized at 24V.

Reference wiring diagram on next page (page 14)

Soft Stop Feature – Wiring Diagram

Figure: Wiring Diagram for Soft Stop Switch on AI3+

Note: Please use Gauge 20, single strand wires for all signal terminals (I/O) on the smart controller. Wires can be a maximum of 300 ft long and must be twisted and ground shielded.

Critical Installation Requirements – Summary Diagram:

**Note: Due to proven lack of power quality from solar regulators, we recommend running the controller 24 VDC power off the batteries directly, not the regulator. Please contact LCO with any questions prior to installation.*

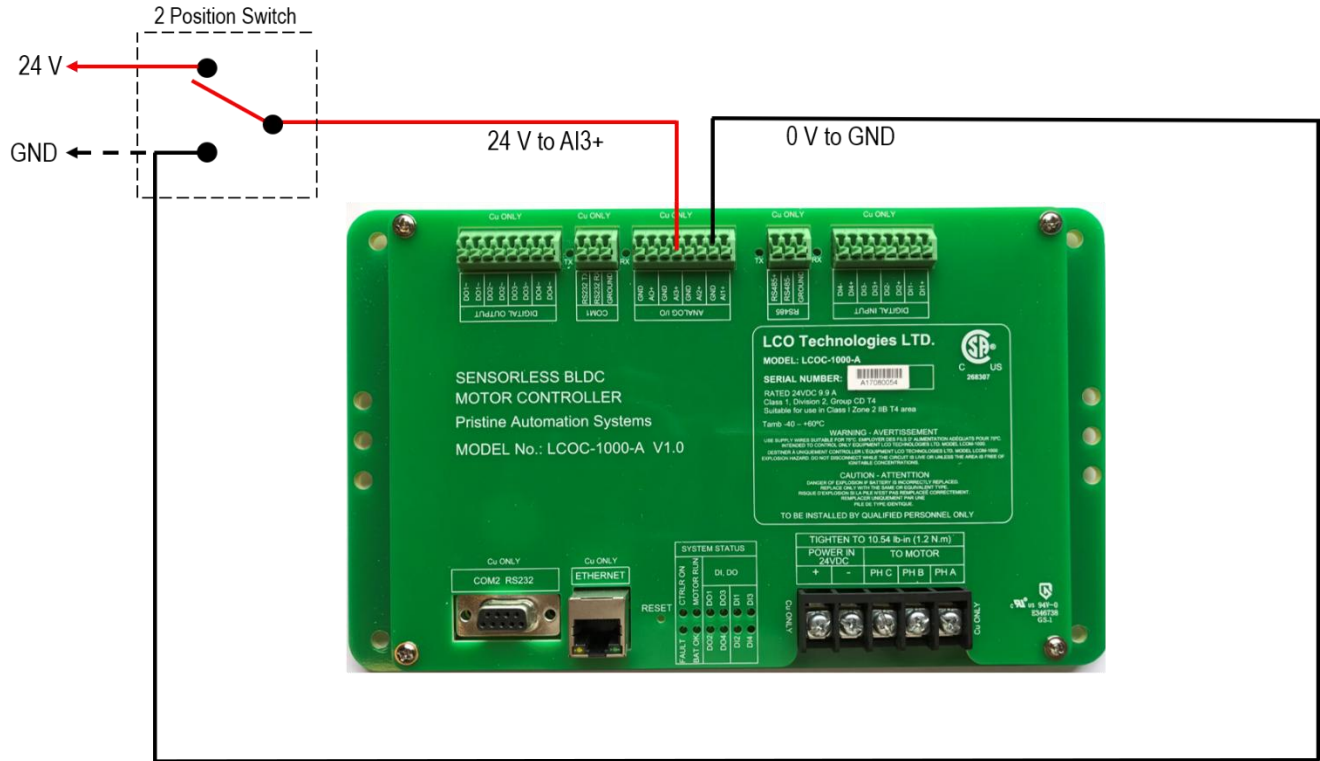
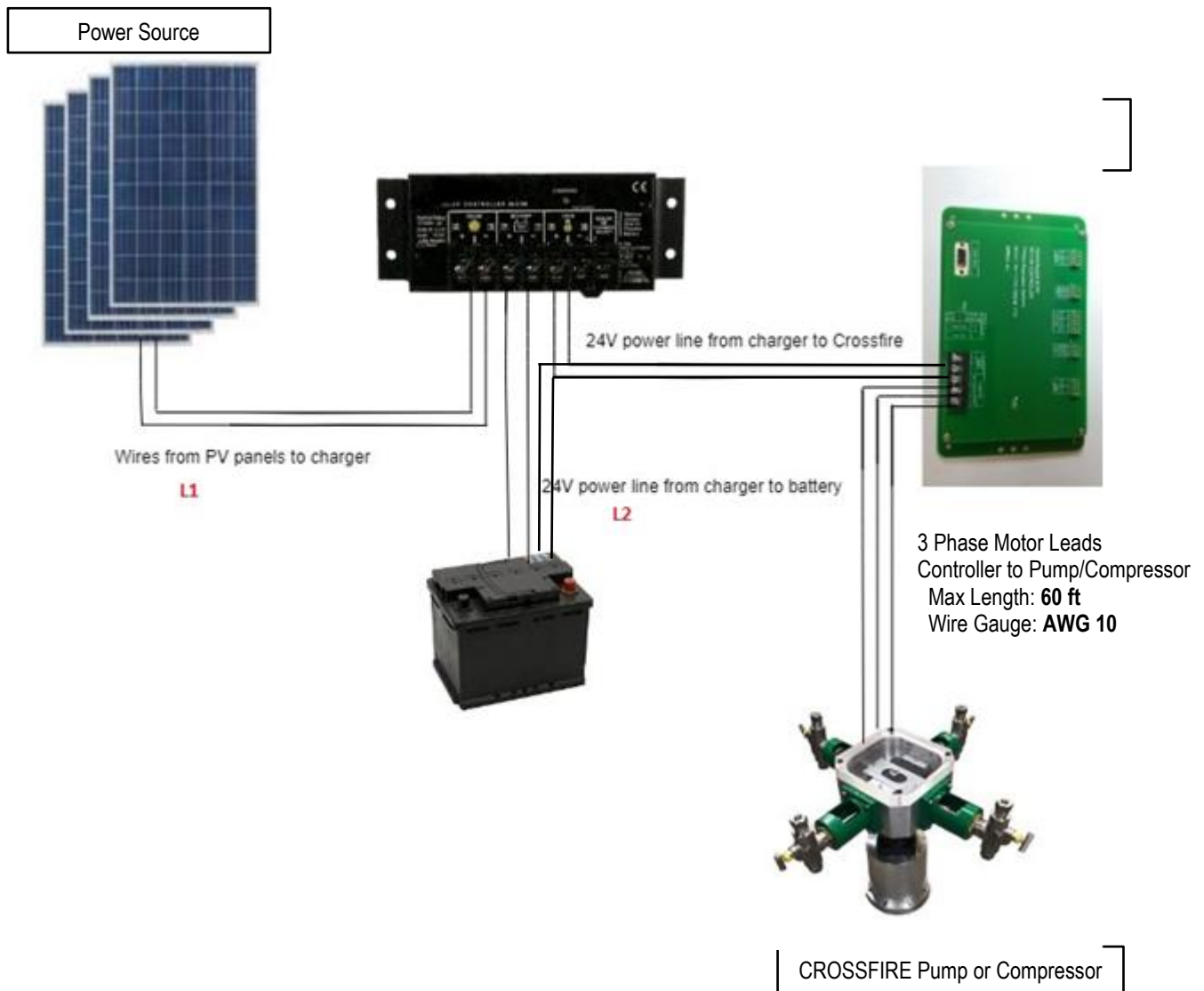
Note: Wiring instructions are per device. Multiple CROSSFIRE units cannot be wired off a single cable run. Any deviation from the above diagram can affect CROSSFIRE performance. Please consult LCO Technologies directly for assistance prior to deviation if required.

CROSSFIRE Pump Start Up

Step 1: Prime the Fluid Ends

- Once fluid ends are tubed, install a 1/8" NPT x 1/4" or 3/8" compression fitting into the threaded outlet of the priming valve. Tube this fitting to capture vented chemical that flows during the priming process.
- Open the priming valve and let the chemical run through the fluid end until you have a steady flow of chemical with no air bubbles. This ensures no vapour is present in the system.
- Close the priming valve

Note: If the pump does not deliver the chemical during this priming process as expected, flood the discharge line with a hand pump connected to the threaded vent of the priming valve. Generally, this step is not required when using 1/2" or 3/8" fluid ends, however when using 3/16" or 1/4" fluid ends, particularly under high pressures, this may be necessary.

Optional Step: Priming with Hand Pump

- Connect the hand pump to the threaded vent on the priming valve
- Open the priming valve
- Push chemical through with the hand pump to completely flood the discharge line

Special Part: LCO Technologies now supplies a plunger disc with every fluid end. This plunger disc helps to prevent chemicals leaking into the top works if a fluid end is leaking. If you do not have one of these plunger discs on an older pump, please contact LCO Technologies and one will be supplied free of charge. Please ensure the plunger disc remains installed.

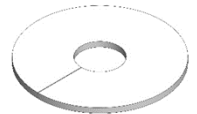

Figure: Plunger disc

Step 2: Start the pump

- Connect an RS 232 cable to the controller and computer
 - Alternative: connect an LCO Bluetooth dongle for wireless communication
- Start up the chemical injection pump as per the interface instructions starting on page 19

Warning: Pinch Hazard

Always keep the clear acrylic top plate on the unit while the pump is running



Step 3: Gauge the Pump

- After setup and installation is complete, run the pump and gauge chemical volume delivery rate
 - Recommended steps:
 - Install a calibrated sight glass
 - Fill the sight glass (the sight glass will fill to match the level in the chemical tank)
 - Isolate the tank
 - Open the isolation valve on the base of the sight glass
 - Close the isolation valve on the chemical tank
 - Run the pump, observe and adjust the chemical delivery rate as required
 - Check for leaks from packing glands and tubing
 - If there are leaks from the packing gland, refer to page 42

Optional Step: Adjustable Thrust Rod Plungers

- Adjustable thrust rod assemblies may be purchased as an optional accessory to allow for more detailed adjustments of chemical volume delivery rates per fluid end
 - By adjusting the stroke length of the plunger, the volume delivered per stroke can increase or decrease proportionately
- Identify if the fluid ends are configured with adjustable thrust rod (ATR) assemblies
 - Visually identified by the threaded thrust rod attached to the plunger with two lock nuts
 - If non-adjustable, there will be no threading on the thrust rod and no lock nuts

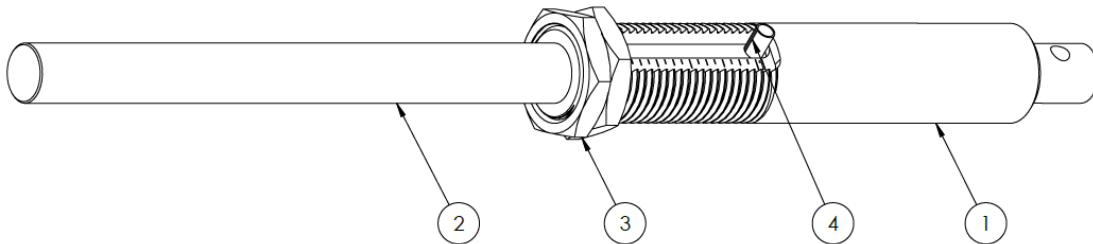

Adjustable Thrust Rod Assembly

Item	Part Number (as Complete Assembly)	Name & Description
1	LCO-ATR-XX	Threaded Thrust Rod
2		Custom Plunger, Extended Length
3		Lock Nuts (qty 2)
4		Half Groove Dowel Pin

- Confirm the two lock nuts are touching and located on the left side of the dowel pin as shown in the graphic above, not on the right side of the dowel pin
- Move the lock nuts along the threaded thrust rod to set the desired stroke length
 - When the lock nuts are closest to the topworks (touching the dowel pin) the stroke length is 1"
 - As the lock nuts move to the left (closer to the plunger and fluid end, away from the top works) the stroke length decreases down to a minimum of 0.35", scaled accordingly in between the two end points
- Tighten the two lock nuts together to secure stroke length position
- Gauge the pump to check chemical delivery rate
 - Adjust the lock nuts as required until chemical delivery rate is acceptable
- Ensure the stroke length is updated and set in the software
 - Additional instructions on page 23

Note: If replacement plungers are required for a pump, ensure that extended plungers for an ATR set are ordered. Regular plungers are shorter and ATR sets require a custom, extended length plunger. We recommend setting the ATR no higher than 0.9" for maximum efficiency and to transition to a standard thrust rod and plunger application for a 1" stroke.

Software Installation:

Step 1: Download the Computer Interface Software

- Go to <https://lcotechnologies.com/resources.html>
- Click on download button and follow all prompted instructions
- ZIP file password: **crossfire2017**
- The Interface is compatible with the following operating systems:
 - Windows 10 or later
- Both the operator and technician tabs are password protected.
 - Operator Password: **Pristine**
 - Technician Password: **Automatic**

Optional: Mobile Application

- In addition to the computer software, there is an identical application for wireless communication to a mobile phone or tablet
- Software requirements:
 - iOS 12 or later
 - Android 7 or later
- Required Parts:
 - BT5-SAI or BT5-PTM
- Download mobile App on **Apple App Store** or **Android App Store**
 - Search “CROSSFIRE” or “LCO CROSSFIRE”
 - Alternative: go to the LCO website <https://lcotechnologies.com/resources.html> and click on the App store link listed under the “Resources” tab
- Both the operator and technician tabs are password protected
 - Operator Password: **Pristine**
 - Technician Password: **Automatic**

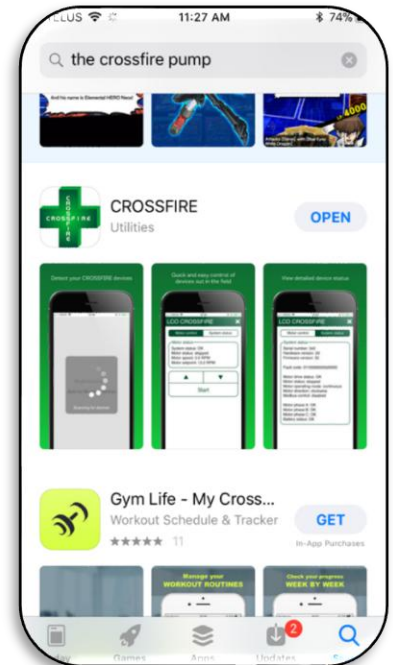

Optional: Wireless Connection to Laptop

- Additionally, customers can communicate from the controller to the computer interface software wirelessly
 - Required parts: BT5-SAI or BT5-PTM and BT5-USB
 - An additional USB dongle is required for laptop communications as laptops do not come standard with the same advanced Bluetooth LE5 protocol as built into the serial dongle
- Download device driver to laptop
 - Go to <https://lcotechnologies.com/resources.html>
 - Click on the link: [Drivers for USB->Bluetooth adapter](#)
 - No password required

For any other information regarding wireless Bluetooth communication and installation details, please refer to the Bluetooth Product Spec Sheet found at:

<https://lcotechnologies.com/resources.html>

Interface Guide

The LCO Technologies *CROSSFIRE* Configuration Software is a tool used to easily monitor and configure the controller that drives the *CROSSFIRE* pump with a RS232 serial connection. Additionally, a mobile version of the software for cell phones and tablets is available using Bluetooth coms.

There are two distinct logins for the interface – technician and operator. Operators have viewing access to all tabs, however, can only make changes within the *motor control* and *system status* tabs. Technicians have access to all tabs and can make changes to all settings, including the more advanced automation features in the *automation* tab.

Interface Overview

The *CROSSFIRE* configuration software is divided into three regions:

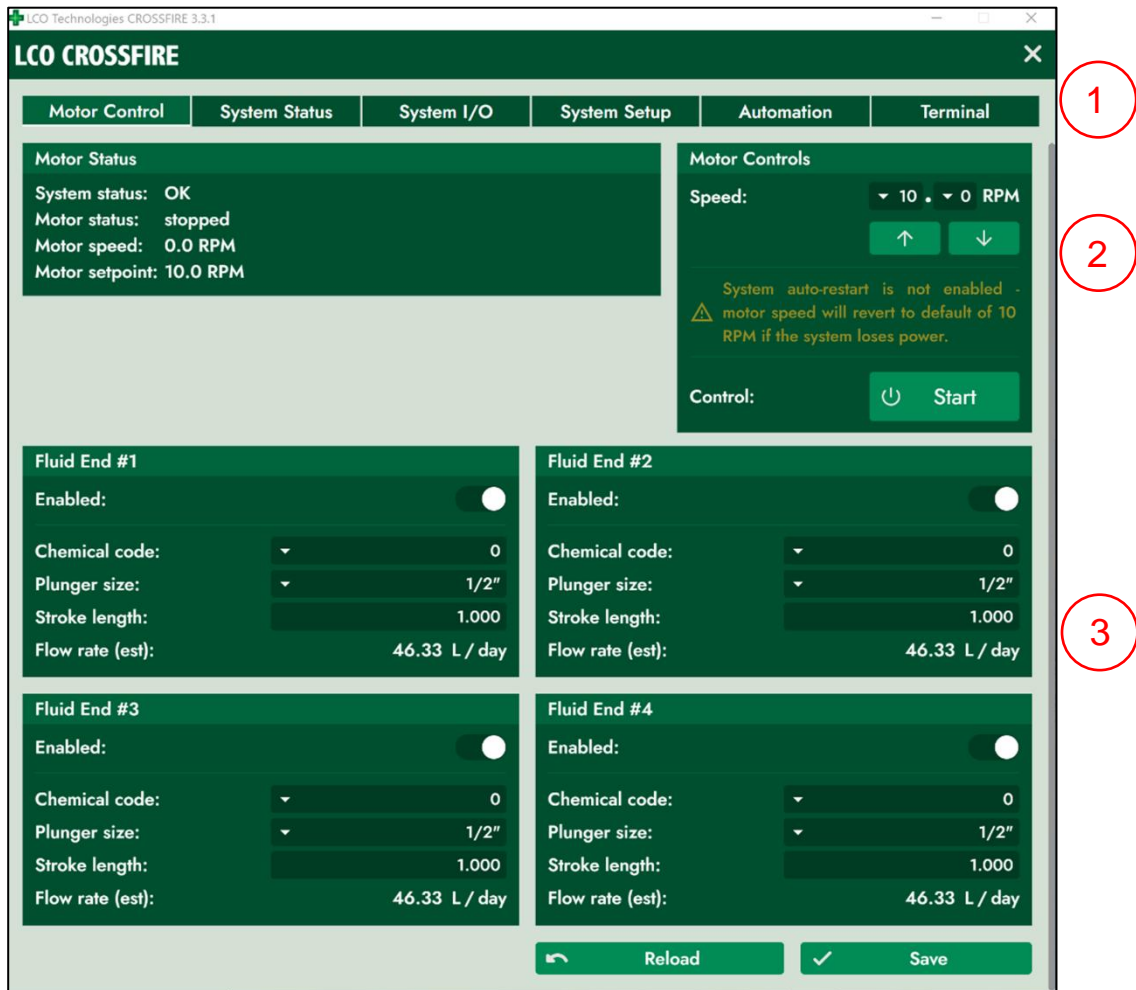

Figure: *CROSSFIRE* Configuration Software main window

- 1) Main menu bar: Used to connect and disconnect from the *CROSSFIRE* controller and switch between operation tabs.
- 2) Motor control panel: Shows motor status and is used to start/stop the motor and set motor speed (available for both operators and technicians). Additionally, will display advanced automation mode instead of speed settings if configured.
- 3) Configuration panel: Used to view and edit the configuration data stored on the *CROSSFIRE* controller (ex. plunger size, and chemical injected)

Main menu

Connect to Controller:

The main screen is used to scan for devices and connect to the *CROSSFIRE* controller and pump. Ensure the pump is powered on and click [Scan for Devices](#), then select the appropriate COM Port.

- See: Troubleshooting – COM Port Issues if needed
- Ensure either a LCO Serial BT dongle (with USB pair if connecting to computer) or a hard-wired RS232 cable is connected to the controller

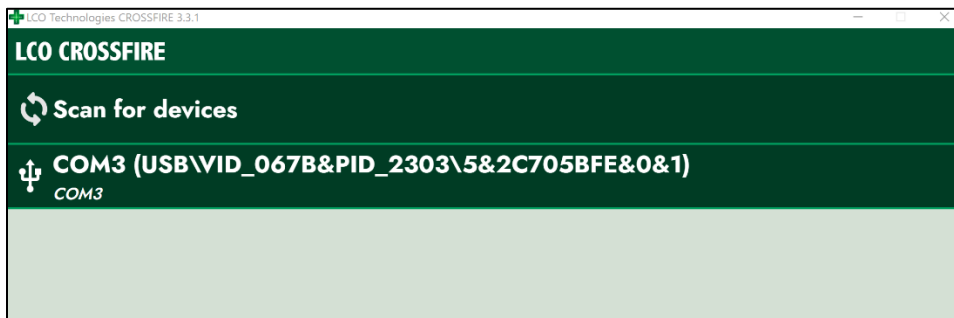

Figure: Computer Interface Main Page – Connecting to a CROSSFIRE Controller



Figure: Mobile App

Log into the Controller:

- 1) Login as: Select [operator](#), or [technician](#). Operators only have access to change basic settings; Technicians have access to change all settings, including advanced configuration options.
- 2) Password: Enter the correct password to log in to the controller as operator or technician.
 - Operator Password: **Pristine**
 - Technician Password: **Automatic**

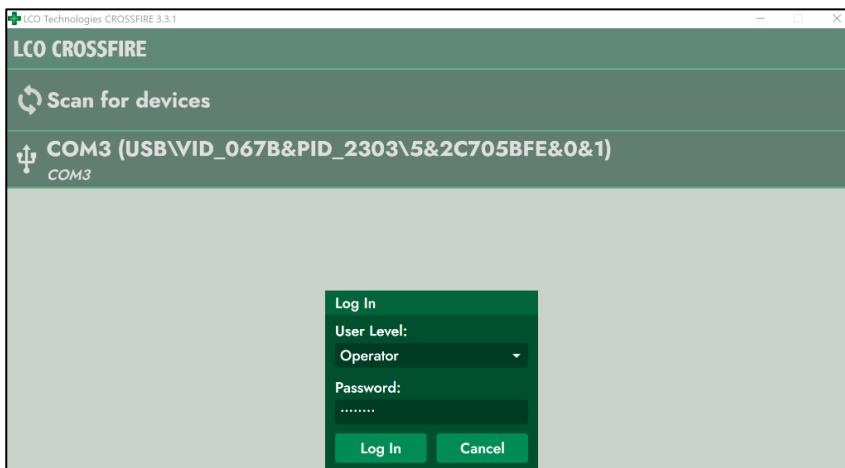

Figure: Computer Interface Main Page – Log in as Operator or Technician

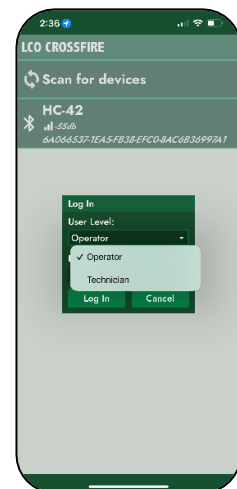

Figure: Mobile App Login

If controller connection is successful, the configuration and status panels will be enabled and will show data from the pump. If the attempt to connect fails, an error message will be displayed (see: Troubleshooting – Connection Errors).

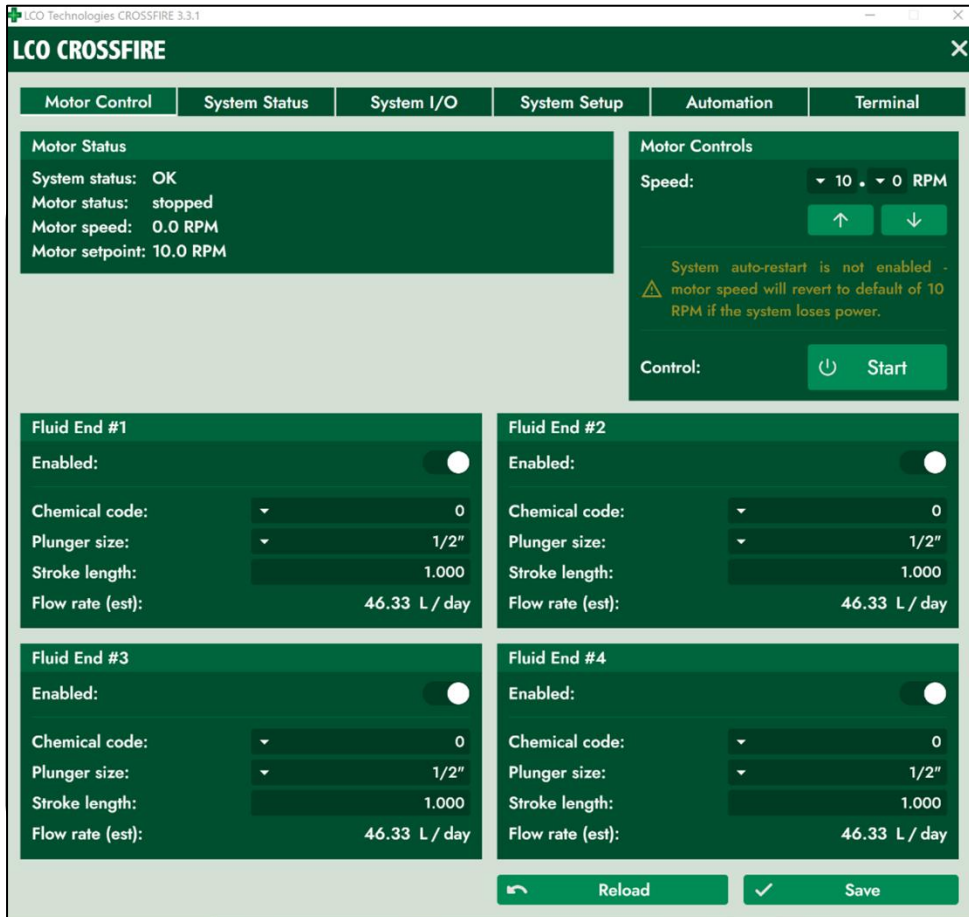

Figure: Computer Interface and App Main Page – Successful Login

Disconnect from Controller:

To disconnect from the controller, click the white X in the top right-hand corner.

Motor Control Tab

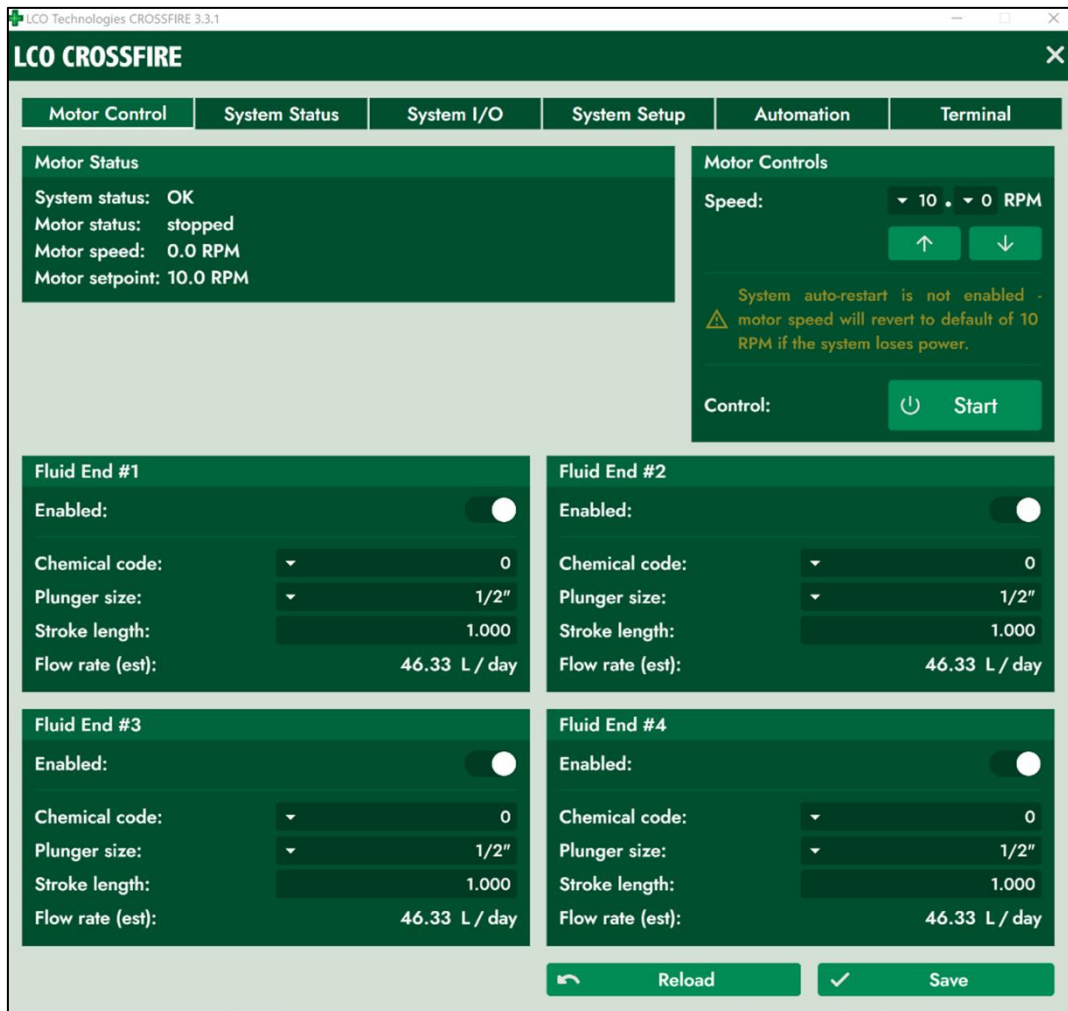

Figure: Motor Control Tab – Pump Setup

The *Motor control* tab is used to specify the physical setup and operational speed of the *CROSSFIRE* platform, and is divided into two regions:

- 1) Fluid end settings: to record configuration of the pump
- 2) Save/reload buttons: to transfer the configuration to and from the *CROSSFIRE* controller.

Note: Fluid end settings are only visible when configured as a pump and are hidden when configured as a compressor.

The **fluid end settings** are used to configure the four fluid ends that can be installed on the *CROSSFIRE* platform. Each fluid end has a separate setup pane:

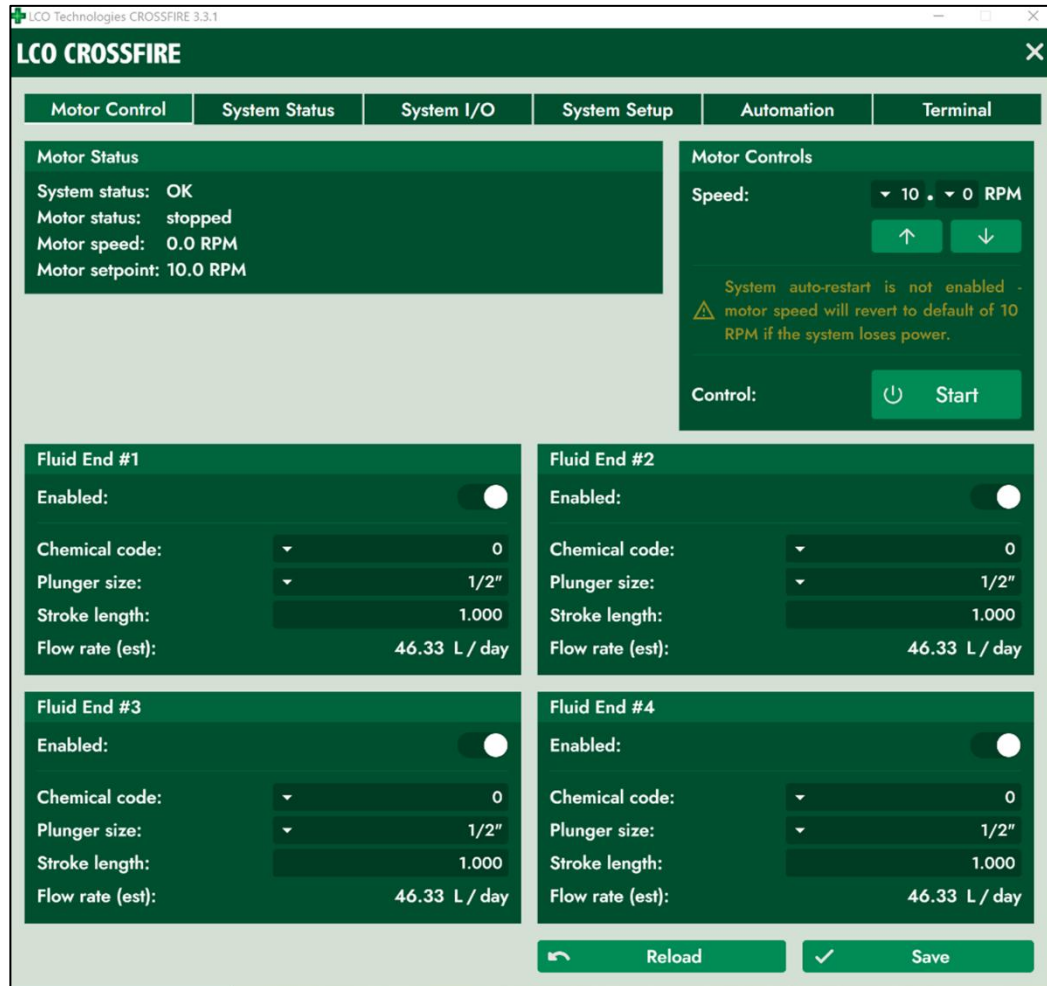



Figure: Motor Control Tab - Pump setup

The *chemical code* dropdown menu is used to indicate chemical type and the *enabled* button is used to indicate whether a fluid end is installed on each of the four available positions. Enabling or disabling the fluid end allows the controller to correctly track the total accumulated number of pump strokes the system has made per motor rotation; thus, it is **critical** to ensure if a fluid end is not present, the fluid end is **disabled and saved**. 

Fluid end *plunger size* and *stroke length* are also recorded here. Based on those parameters in addition to speed of the pump, an estimated delivery rate will be displayed. The standard gearbox installed on the *CROSSFIRE* platform allows the system to be run between 1 and 45 RPM. *Stroke length* by standard is 1", however can range from between 0.35"-1.00" when an adjustable stroke length plunger is installed.

Note: The *flow rate* listed is a theoretical calculation based on operation parameters, and actual volume delivered may vary from this depending on factors such as system pressure and packing materials used in the fluid end.



Figure: Save/Reload buttons

The *Save* button saves any changes made to the fluid end settings and pump speed to the configuration data saved in the controller.

The *Reload* button reloads the saved configuration data from the controller.



Warning: Any unsaved changes made to the settings will be lost. The user must press save to send changes made in the software to the controller.

Motor Control Panel

The *motor status* panel is used to configure and check the status of the system drive motor:

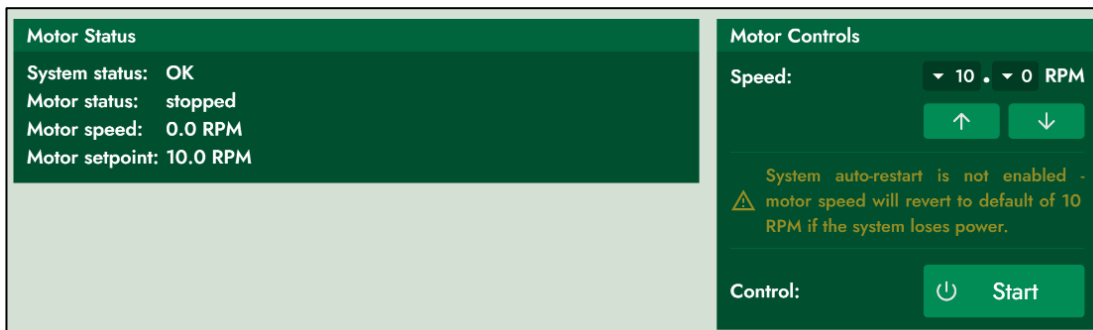

Figure: Motor control panel

When connected to the controller, the *start/stop button* will start or stop the motor when the controller is connected and online. The *motor speed selection* configures the RPM setpoint of the motor and can be changed from the drop-down menu or the up and down arrow buttons.

Note: This panel will change based on the automation mode configured. For example, if the chemical pump is configured in proportional control mode, the motor status will reflect the active configuration.

System Status Tab

The [system status](#) panel provides detailed status and diagnostic information about the motor, controller and power available on-site:



Figure: System status tab

[System status](#) shows the unique serial number, hardware, firmware, and uptime of the connected controller and the configured state of the pump hardware. It also shows the total rotation count and total stroke count for the device.

[System diagnostics](#) displays the current system status code; underneath, a detailed breakdown of the code will describe system condition any detected faults if applicable. This information is updated every few seconds. The most recent fault record is listed below if applicable.

[Power details](#) displays details about the power available on-site, battery voltage and current.

Warning: Total stroke count is based on the number of enabled fluid ends in the [motor control](#) tab at the time of each motor revolution. It is critical that the actual number of fluid ends installed on the pump and the number of fluid ends enabled or disabled in the software match to ensure accurate count.



System Setup Tab

The [System setup](#) tab allows for setup and configuration of some advanced controller features, download of record and system reports, and is divided into five regions:

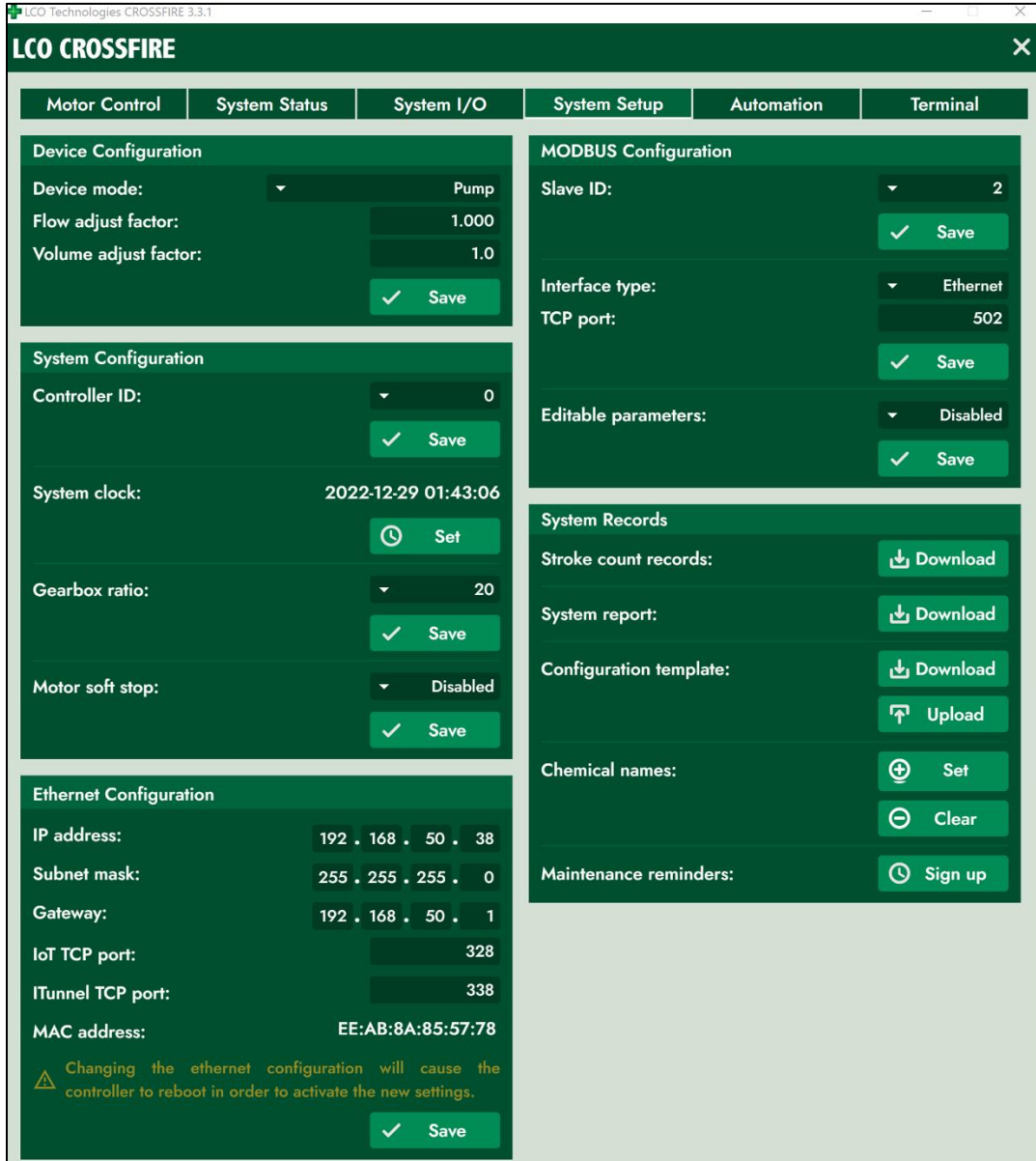

The screenshot shows the 'LCO CROSSFIRE' software interface with the 'System Setup' tab selected. The interface is organized into five main regions:

- Device Configuration:** Includes 'Device mode' (set to Pump), 'Flow adjust factor' (1.000), and 'Volume adjust factor' (1.0). A 'Save' button is present.
- System Configuration:** Includes 'Controller ID' (0), 'System clock' (2022-12-29 01:43:06), 'Gearbox ratio' (20), and 'Motor soft stop' (Disabled). Each parameter has a 'Save' button.
- Ethernet Configuration:** Includes 'IP address' (192.168.50.38), 'Subnet mask' (255.255.255.0), 'Gateway' (192.168.50.1), 'IoT TCP port' (328), 'ITunnel TCP port' (338), and 'MAC address' (EE:AB:8A:85:57:78). A warning message states: 'Changing the ethernet configuration will cause the controller to reboot in order to activate the new settings.' A 'Save' button is at the bottom.
- MODBUS Configuration:** Includes 'Slave ID' (2), 'Interface type' (Ethernet), 'TCP port' (502), and 'Editable parameters' (Disabled). Each parameter has a 'Save' button.
- System Records:** Includes 'Stroke count records', 'System report', 'Configuration template', 'Chemical names', and 'Maintenance reminders'. Each has a corresponding 'Download', 'Upload', 'Set', 'Clear', or 'Sign up' button.

Figure: System Setup Tab

- 1) Device configuration
- 2) MODBUS configuration
- 3) System configuration
- 4) System records
- 5) Ethernet configuration

Note: When logged into the software as an operator, these parameters are read only. The user must be logged in as a technician to make changes to the following parameters in this tab.

The *device configuration* settings are used to set the main operating device mode and change flow parameters.

- *Device mode* is used to select between pump or compressor modes
- *Flow adjust factor* and *Volume adjust factor* are used for finite adjustment of volumes if thermodynamically required. The factors default to 1.0 and can be modified if required.

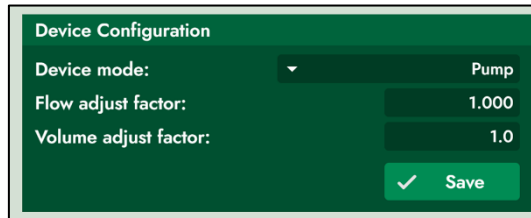

Figure: System Setup Tab – Device Configuration Section

The *MODBUS configuration* settings are used to view and change the settings of the controller’s MODBUS port, to properly integrate it with the SCADA system on-site. Use the *interface type* drop down menu to select whether MODBUS communications will be over RS485 or Ethernet (advanced controller model only).

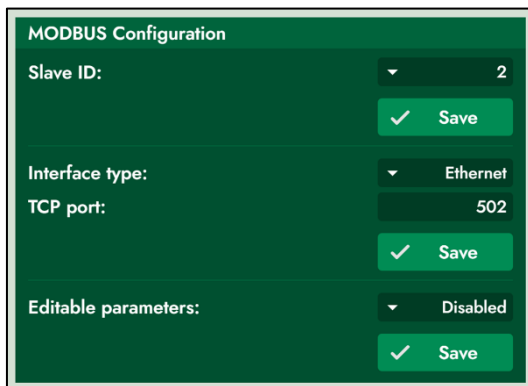
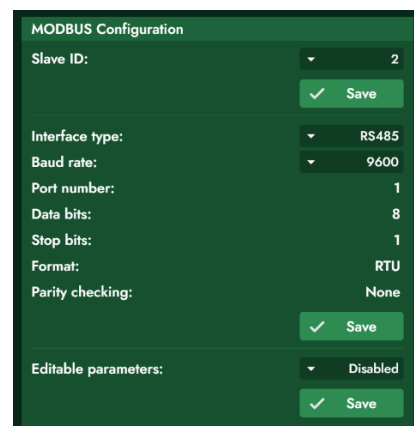



Figure: System Setup Tab – Modbus Configuration Section – Ethernet versus RS485

Configurable options include *TCP port*, *editable parameters*, *slave ID*, *baud rate*, *port number*, *data bits*, *format*, and *parity checking*. The *Save button* will save the settings to the controller.

The *system configuration* settings are used to edit parameters such as:

- *Controller ID number*: used to assign a number to the controller (any value between 0 to 255)
- *System clock*: set the controller’s system clock to the current date and time
- *Gearbox ratio*: specifies the gear ratio of the installed gearbox on the motor (standard pump ratio is 20:1)
- *Motor soft stop*: used to stop the pump without powering down the controller and losing MODBUS communications (not positive isolation, on/off switch functionality only). See additional information on page 13-14.

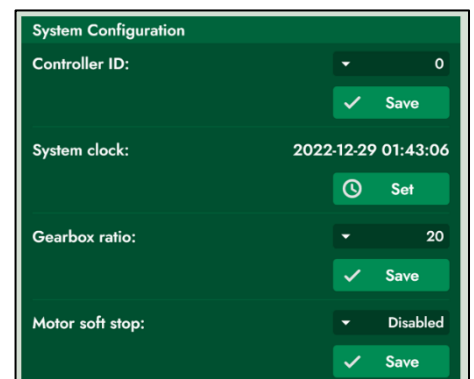

Figure: System Setup Tab – System Configuration Section

The *Systems record* section allows users to download a daily *stroke count record* log and full *system report*. By clicking download, the report will automatically save to your desktop computer. In addition, this is where users can upload or download a *configuration template*, set *chemical names*, and sign up for *maintenance reminders*.

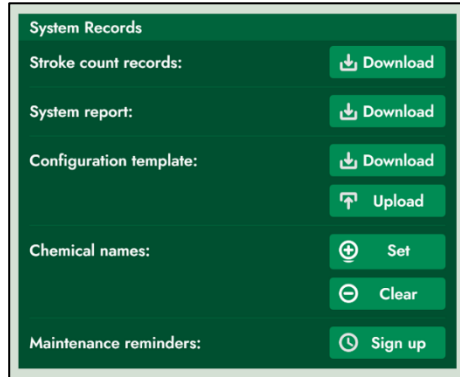

Figure: System Setup Tab – System Records Section

Note: For mobile users, the app has an option to email or save the downloaded records. For iPhone users, the app will automatically save a copy of the file to the device, which can be found in the iOS system files app under “On My iPhone > CROSSFIRE > SystemReports”.

The *Ethernet configuration* section allows technicians to view and change the settings related to the Ethernet connection. This is for customers using Ethernet MODBUS communications (MODBUS/TCP) and is available on advanced controllers with firmware V38 or later only. Editable parameters include *IP address, subnet mask, gateway, IoT TCP port, and ITunnel TCP port*. *MAC address will auto populate*. If connecting controller direct to IOT Ethernet, contact LCO for specialized instructions and assistance.

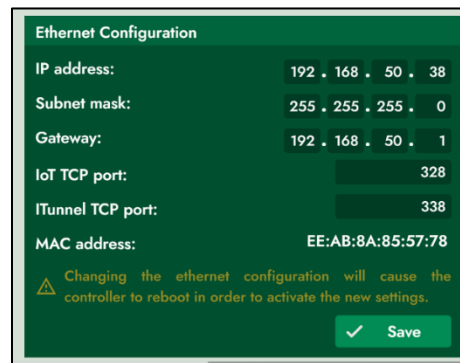

Figure: System Setup Tab – Ethernet Configuration Section

System I/O Tab

The [System I/O](#) tab is used to view the state of the controller's discrete input, discrete output, analogue inputs, and analogue output pins. Inputs will auto-populate when connected to the controller and [analogue in setup](#) can be used to specify whether the incoming signal is 4-20mA or 0-5V. [Analogue out setup](#) is only available for advanced controllers. [Digital out setup](#) is available unless another advanced automation function that uses a digital out is not enabled within the [Automation](#) tab (such as Motor Run Light, Drain Valve Control, MODBUS IO Control, Solenoid Bypass Control etc.) If an advanced automation function is already enabled (more details on page 30), the software will not display [digital out setup](#) settings accordingly.

Additional specific control applications can be exercised under the [Terminal](#) tab to configure a wide variety of process logic parameters. Please contact LCO Technologies directly for assistance with I/O configuration.

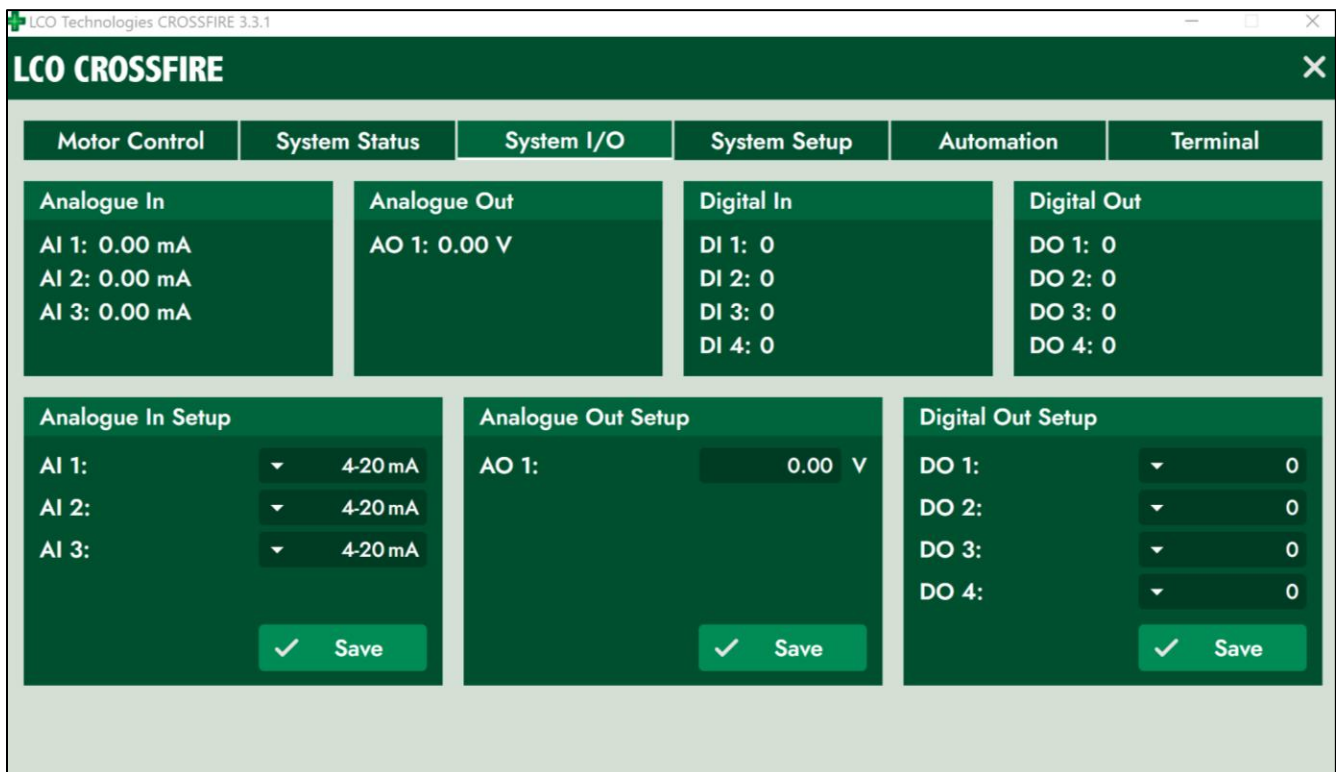

Figure: System I/O Tab

Note: Monitored values are refreshed every few seconds that the System I/O tab is open



Automation Tab

The [automation](#) tab is only available to Technicians. This allows selection and configuration of the more advanced modes and settings. This includes [manual control](#) mode, [proportional control](#) mode, [plunger lift control](#), [potentiometer control](#), [toggle switch control](#), and [local remote switch control](#). There are also four [auxiliary control functions](#) in the right section, viewable in all advanced automation modes to control additional functions.

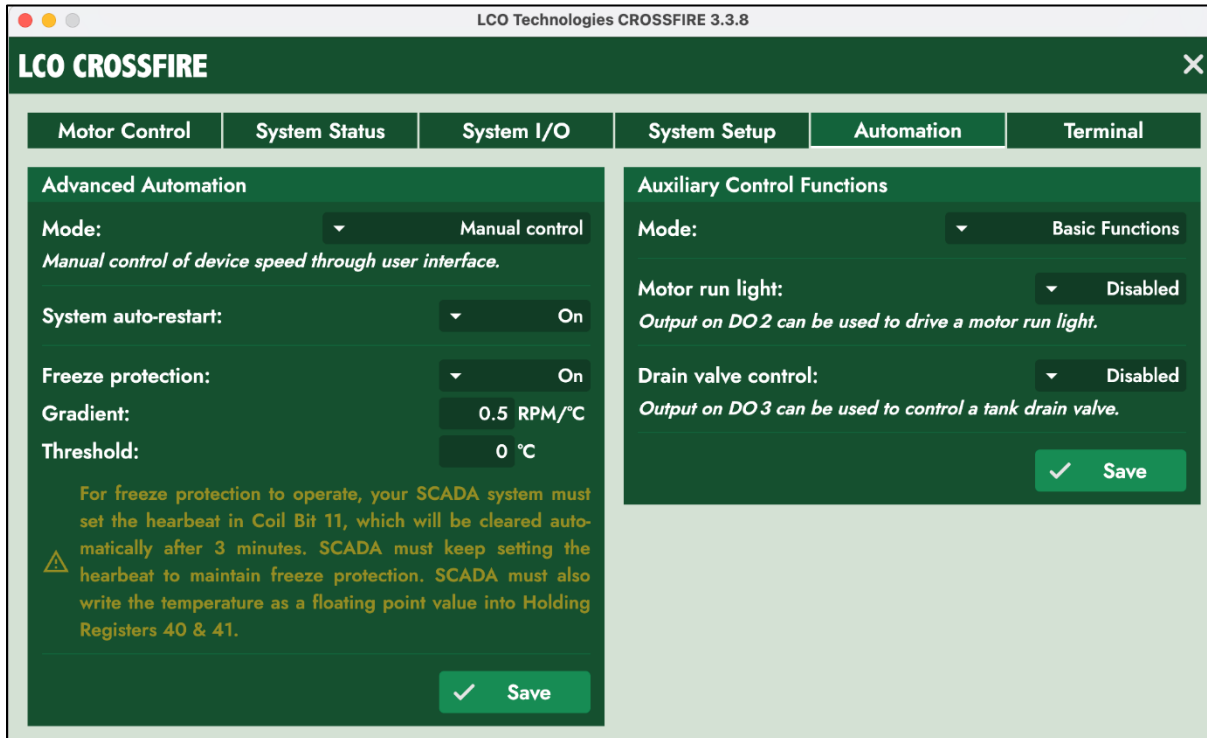

Figure: Automation Tab – Advanced Automation Section – Manual Control Mode

In [manual control](#) mode, all settings such as pump on/off and motor speed are controlled in the main [motor control](#) tab. By default, if the system has a power loss event, the pump will shut off and not start back up, even if 24V of power comes back on. To enable the pump to automatically start up after a system power loss, click the [system auto-restart](#) drop-down menu from OFF to ON and press [save](#) to finalize change.

[Freeze protection](#) mode is a function used to automatically and proportionally increase the volume of chemicals injected based on a drop in temperature. The temperature reading can either come from the controller itself if available (firmware V38 or later) or from a separate temperature sensor on-site, communicated to the *CROSSFIRE* through SCADA. The most accurate temperature reading is from inside the process line on-site. Set [gradient](#) to indicate the increase in motor speed per drop in temperature (1C°) and set the temperature [threshold](#), which means any temperature below that value, engages the freeze protection mode. Press [save](#).

The *Proportional Control* feature allows the motor speed to be driven by a value applied to the controllers *Analogue Input 1*. As the analogue value changes, the motor speed will automatically change accordingly.

Select the appropriate input *mode* (4-20mA or 0-5V) and type the requested *speed* at corresponding analogue input signal. As changes are made, the visual graph will display the proportional control curve. Once the two end point parameters are defined, press *save* to engage function. The motor speed will automatically scale between the defined parameters.

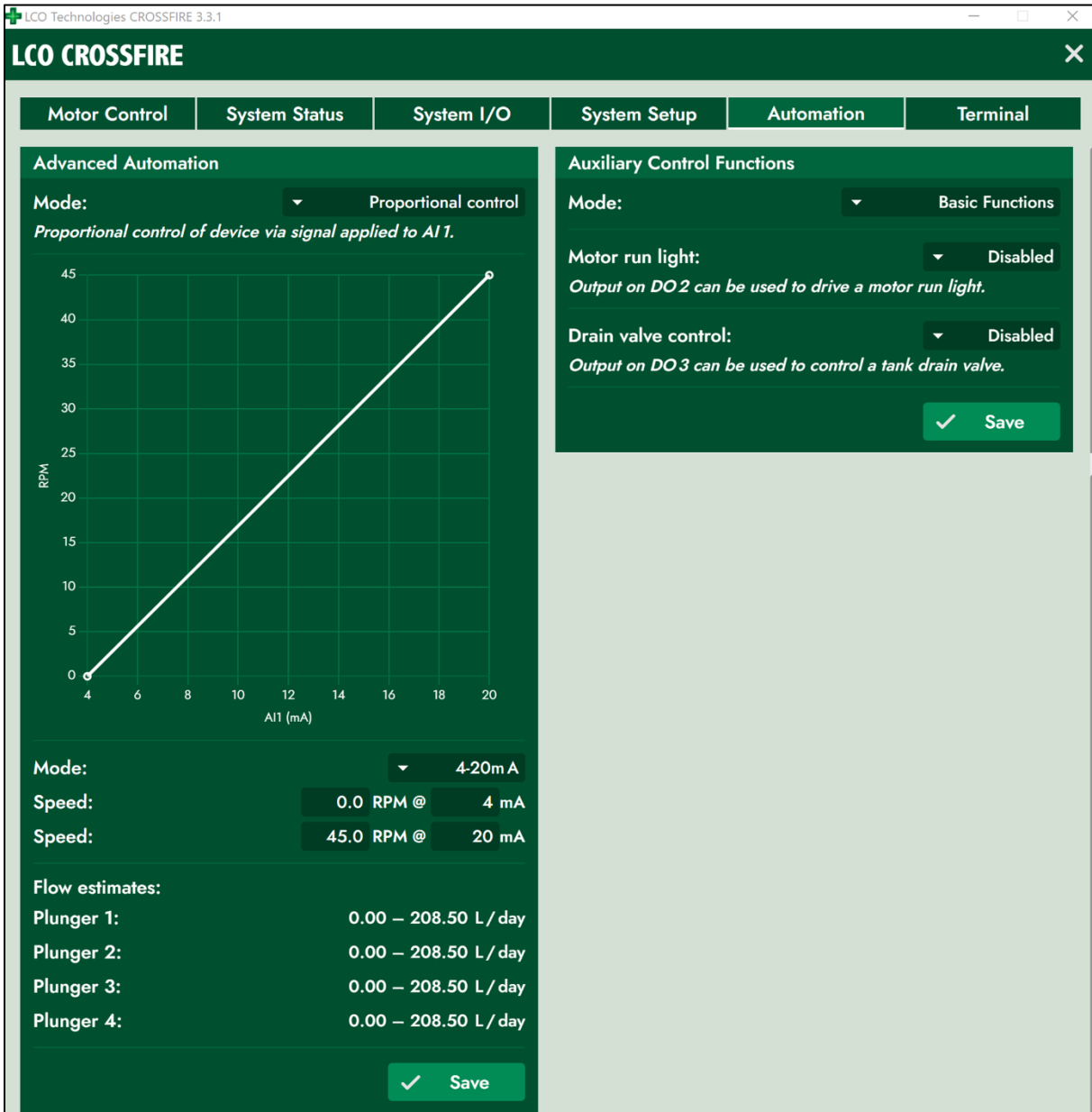

Figure: Automation Tab – Advanced Automation Section – Proportional Control Mode

Note: When in proportional control mode, system auto restart function (as described on page 30) is automatically engaged.

The *plunger lift control* function is used to automatically inject chemical at a set RPM for a specified time period once the plunger drops. Connect the plunger lift controller to the D1²⁺ terminal on the *CROSSFIRE* controller and select the *mode* and *speed*. Press *save* to activate the function. Please contact LCO Technologies directly when engaging this function for further instructions.

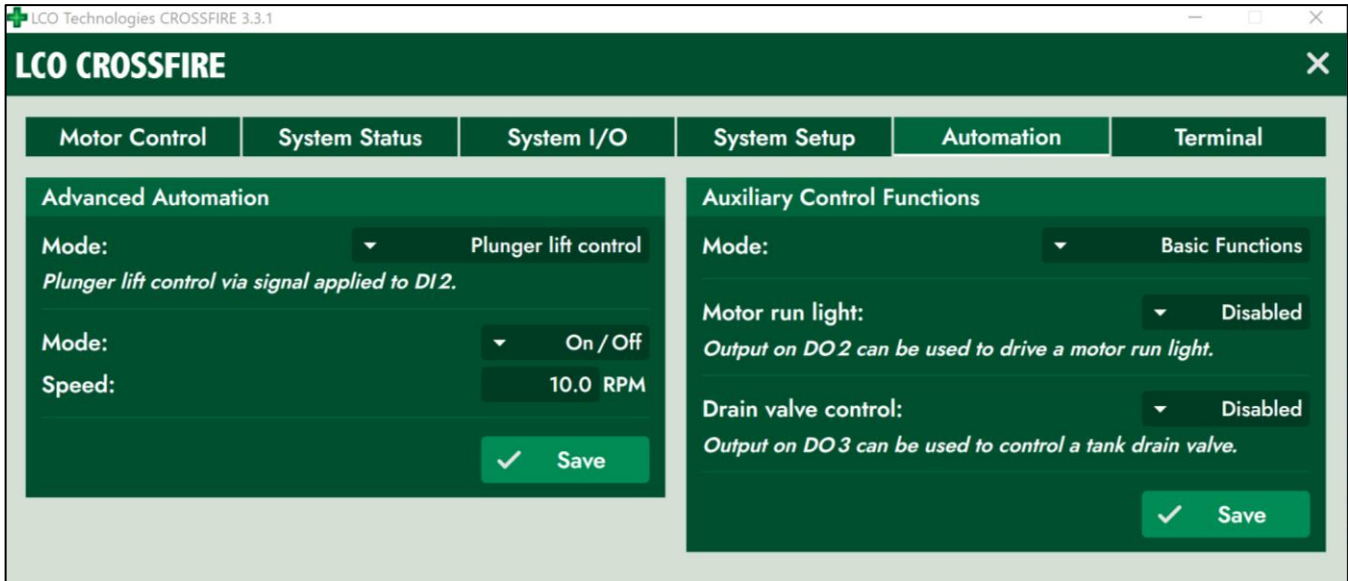

Figure: Automation Tab – Advanced Automation Section – Plunger Lift Control

The *potentiometer control* function is a special feature that requires additional instruction from LCO Technologies. Please contact the factory for assistance.

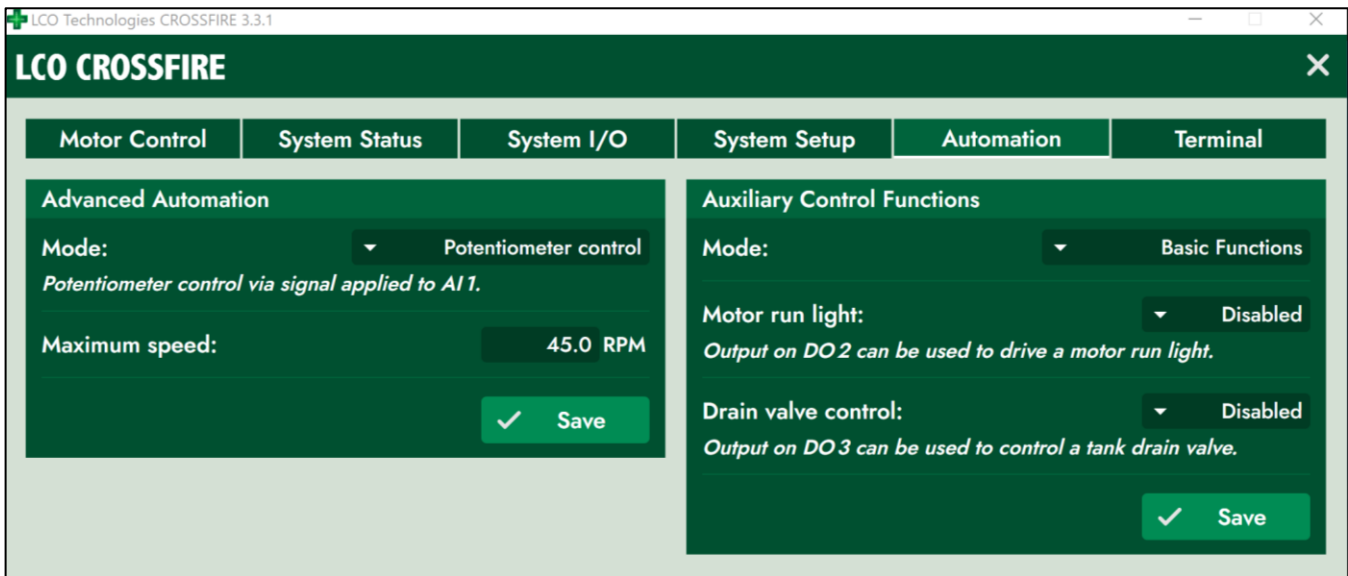

Figure: Automation Tab – Advanced Automation Section – Potentiometer Control

The *Toggle Switch Control function* allows motor speed to be manually controlled by a momentary contact switch on the outside of the electrical NEMA 4 panel. Ensure the switch is connected to the DI1 and DI2 ports on the controller. Once connected, select the *toggle switch control* function from the drop-down menu, set your *Maximum speed* (45 RPM or less) and press *save* to engage function. Each click of the toggle switch up or down will equal 0.5 of an RPM. Ensure appropriate labels are applied to the panel so Operators can easily identify up/down directions and that each click represents 0.5 RPM.

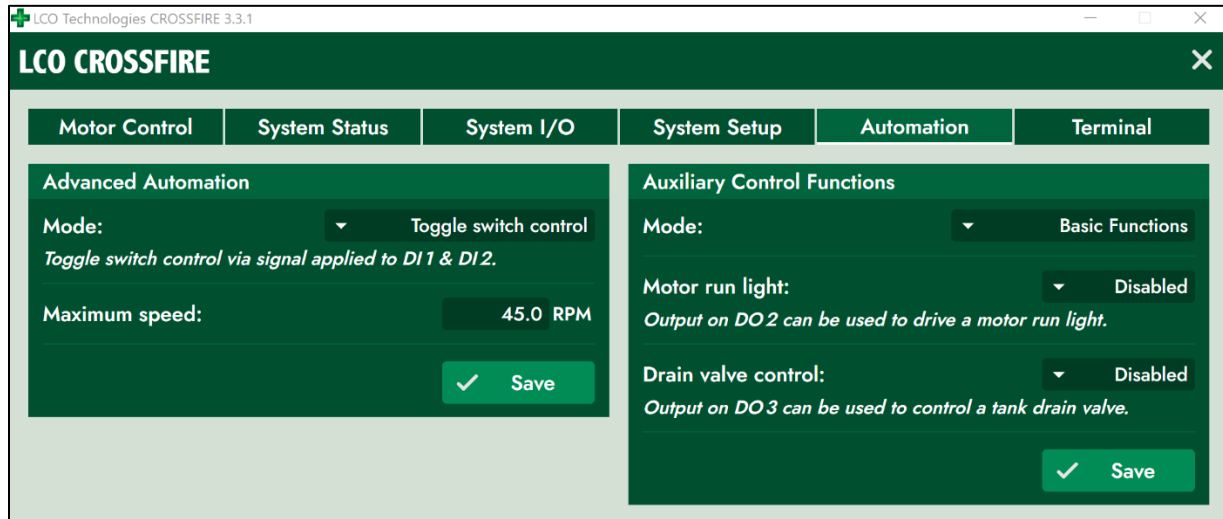

Figure: Automation Tab – Advanced Automation Section - Toggle Switch Control

Local Remote Switch Control is a function that must be engaged when connecting the *CROSSFIRE* to a remote-control monitoring system. By connecting a two-position selector switch and 24VDC to the DI1 terminal on the controller, operators can manually switch the control from remote to local before completing any maintenance on the pump. Select *Local/Remote switch control* from the drop-down menu and press *save* to engage function.

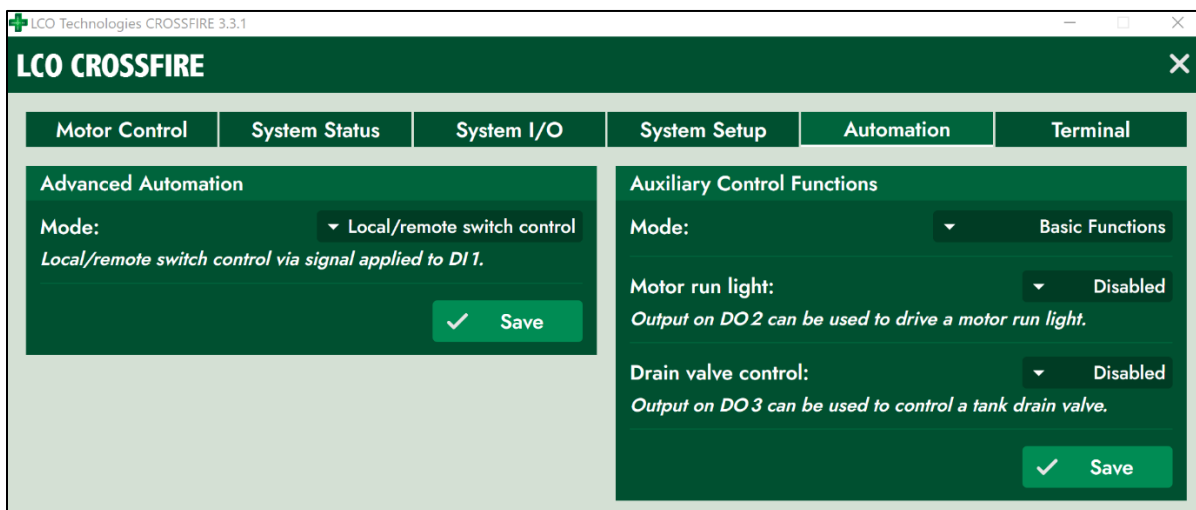
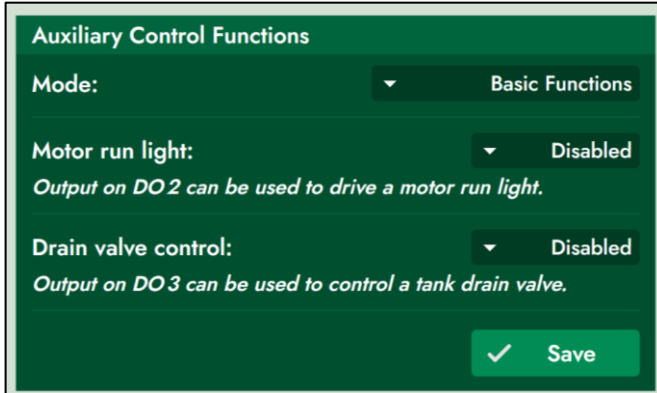

Figure: Automation Tab – Advanced Automation Section – Local/Remote Switch Control

The following four modes in the *auxiliary control functions* section are available regardless of which advanced automation mode is selected. The four modes are: *basic functions*, *sticky DO*, *MODBUS IO control*, and *solenoid bypass control*. Contact LCO Technologies directly for further instructions on setup and use of these features.



Auxiliary Control Functions

Mode: Basic Functions

Motor run light: Disabled
Output on DO 2 can be used to drive a motor run light.

Drain valve control: Disabled
Output on DO 3 can be used to control a tank drain valve.

Save

Figure: Automation Tab – Auxiliary Control Function Section – Basic Functions

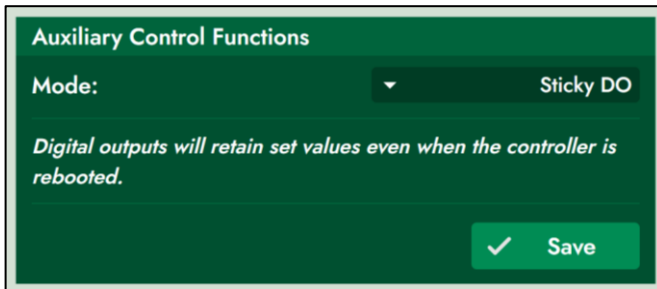

Auxiliary Control Functions

Mode: Sticky DO

Digital outputs will retain set values even when the controller is rebooted.

Save

Figure: Automation Tab – Auxiliary Control Function Section – Sticky DO

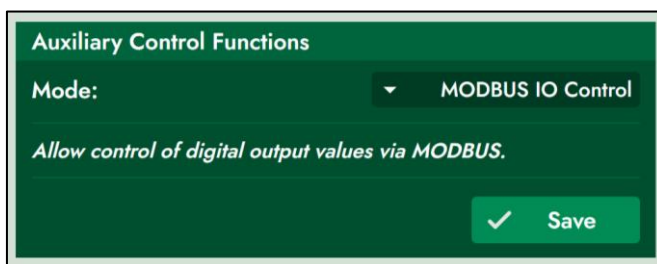

Auxiliary Control Functions

Mode: MODBUS IO Control

Allow control of digital output values via MODBUS.

Save

Figure: Automation Tab – Auxiliary Control Function Section – MODBUS IO Control

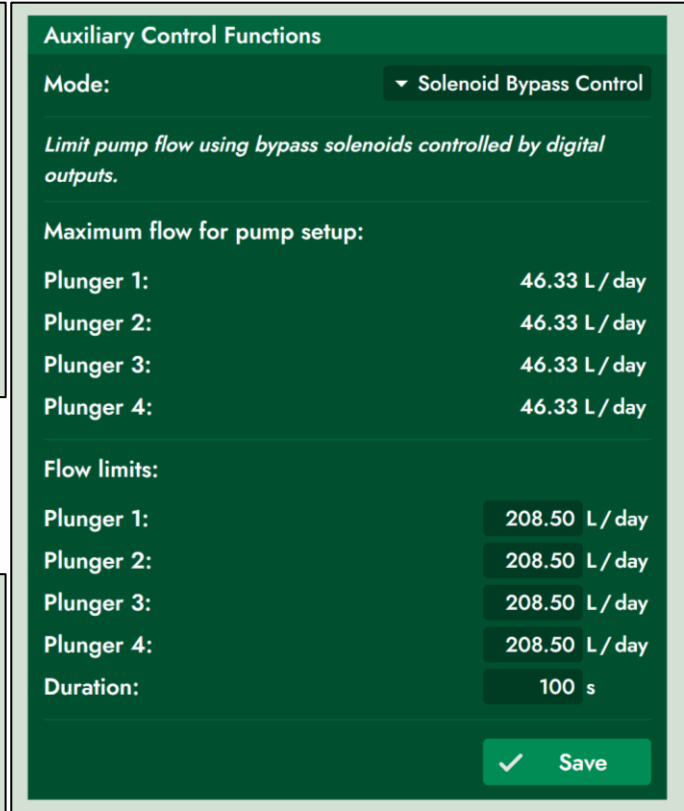

Auxiliary Control Functions

Mode: Solenoid Bypass Control

Limit pump flow using bypass solenoids controlled by digital outputs.

Maximum flow for pump setup:

Plunger 1:	46.33 L / day
Plunger 2:	46.33 L / day
Plunger 3:	46.33 L / day
Plunger 4:	46.33 L / day

Flow limits:

Plunger 1:	<input type="text" value="208.50"/> L / day
Plunger 2:	<input type="text" value="208.50"/> L / day
Plunger 3:	<input type="text" value="208.50"/> L / day
Plunger 4:	<input type="text" value="208.50"/> L / day
Duration:	<input type="text" value="100"/> s

Save

Figure: Automation Tab – Auxiliary Control Function Section – Solenoid Bypass Control

Terminal Tab

The [Terminal](#) tab is available to both Operators and Technicians however, the commands will be limited when logged in as Operator. This tab allows users to by-pass any software selections and speak directly to the controller. This tab can be used for troubleshooting to determine if communication errors exist on the controller or software and can also be used for more advanced configuration such as I/O commands specific to applications.

The [terminal](#) section is where the commands are sent and received. The [reference](#) section lists the most common commands and gives a brief description of their function. For a full list of terminal commands please contact LCO Technologies directly.

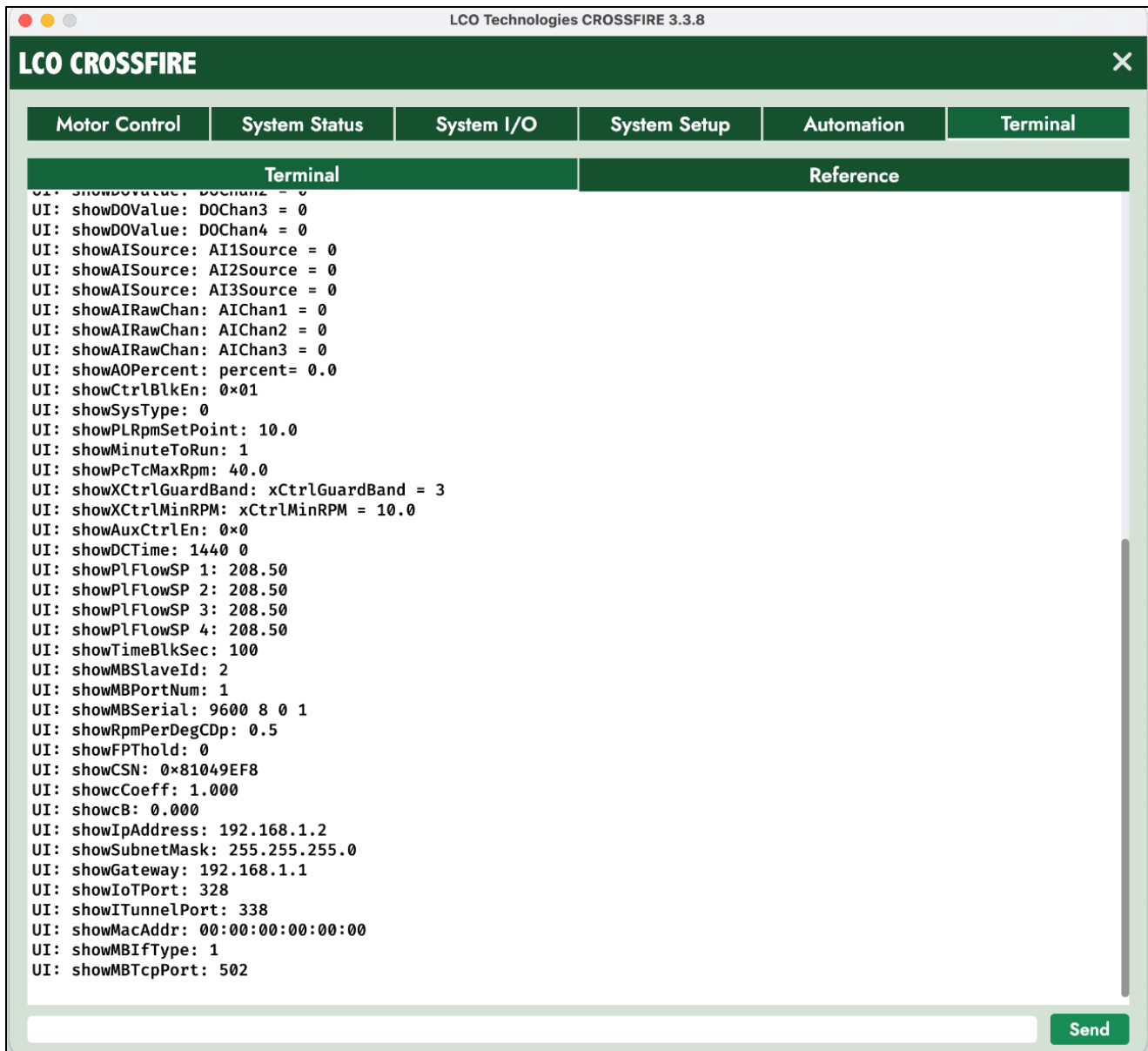

Figure: Terminal Tab – Terminal section

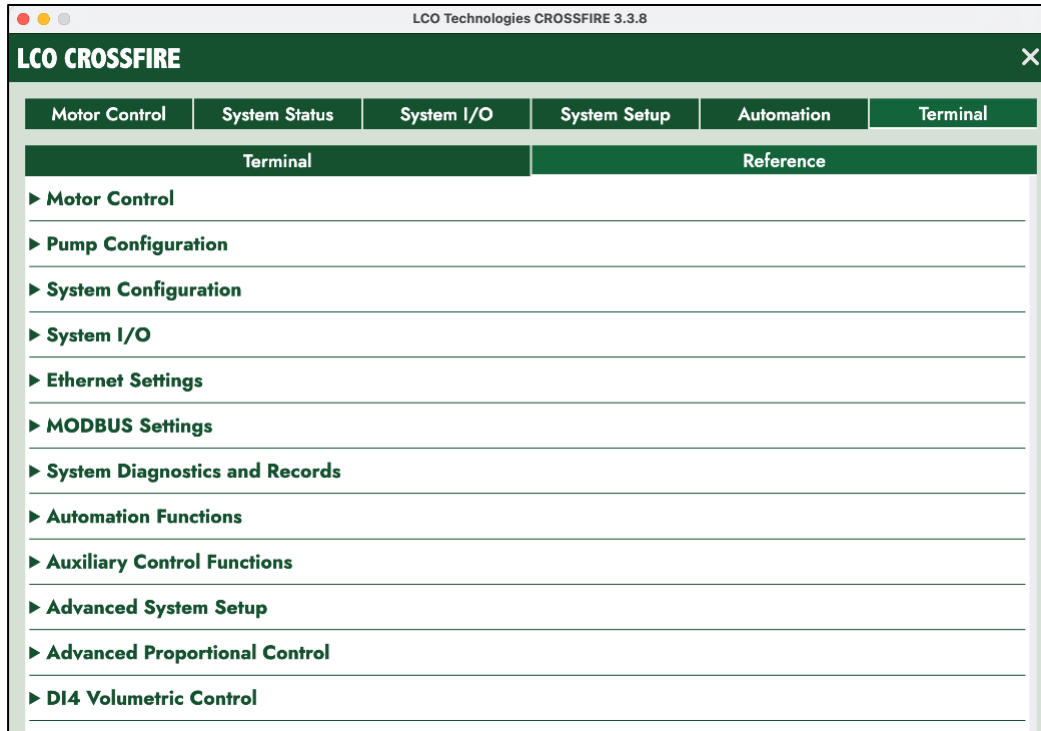

Figure:

Tab – Reference Section

Terminal

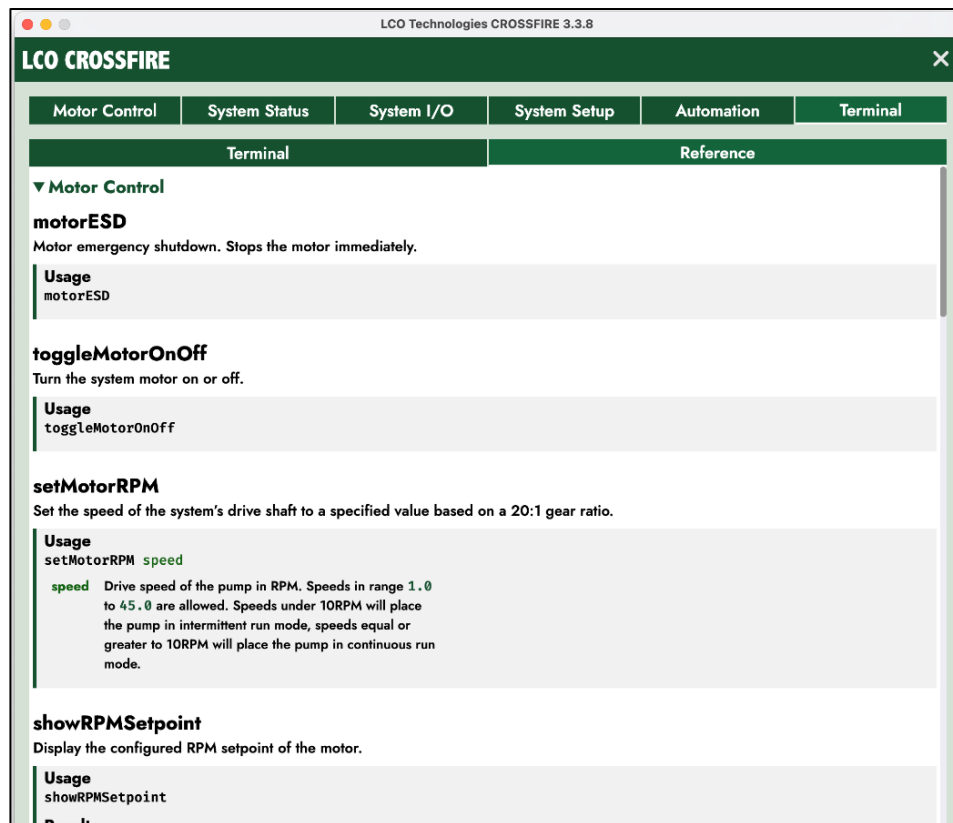
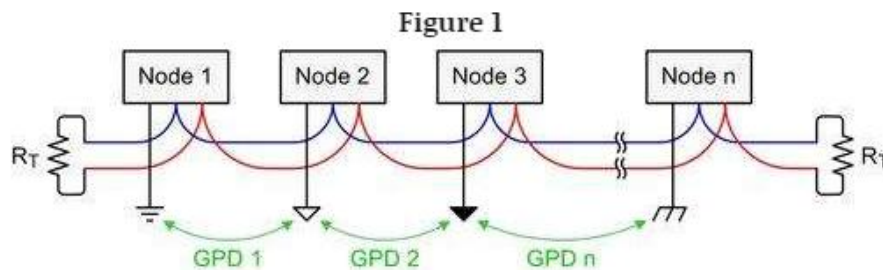

Figure: Terminal Tab – Reference Section – Motor Control Commands

Frequently Asked Questions: Automation & MODBUS

- Q: Can the controller firmware be upgraded on-site?
 - A: The controller firmware can only be upgraded on-site if it is version V38 or later. Controller versions V37 or prior do not have the bootloader technology. If you would like to upgrade your V38 (or later) controller on-site to the most up-to-date firmware and additional features, please follow the instructions on page 52 for a step-by-step guide.
- Q: Can you tie multiple CROSSFIRE controllers on the same RS485 Modbus?
 - A: Yes, you can daisy chain multiple CROSSFIRE controllers on the same Modbus even with other devices set up as Modbus slaves. However, you can only daisy chain a maximum of 10 devices. Every slave must have a unique Modbus Slave ID, from 1 to 247. 0 is reserved for the master. Default slave ID is 2 for the CROSSFIRE Controller.
- Q: Do you need to connect the GND terminal on the RS485 port?
 - A: No, connecting GND terminal is not mandatory for the 2-Wire RS485 bus. If the Modbus has multiple slaves and the site is electrically noisy, connecting all the slaves' RS485 GND to the master RS485 GND may help to improve Modbus communication. Ensure that the RS485 GND is never connected to the power supply ground or the safety ground.
- Q: Does the Modbus need to be terminated?
 - A: Yes, the trunk of this RS485 based Modbus should be terminated on both ends with a 120 Ohm resistor across RS485+/A+ and RS485-/B-. This usually means the master or RTU and the last slave at the end of this RS485 bus.



- Q: What are the valid baud rates and serial com settings?
 - A: Default is 9,600. Other choices are 14,400 and 19,200. 8 data bits, no parity, 1 stop bit and no flow control.
- Q: How often can you poll a CROSSFIRE controller?
 - The CROSSFIRE controller can be polled every 500ms
- Q: Can you poll all the registers provided by the CROSSFIRE Controller?
 - Yes, you could poll all 300+ registers **but we do not recommend this** as it will severely slow down Modbus communication due to the heavy traffic on the RS485 bus. There is no reason to poll all the registers, as most sites require 40 registers or less to fully control and monitor a pump on-site. We recommend you choose the most important

registers. **To reduce power consumption we have limited the maximum number of read or write registers to 8 per poll when connected via serial RS485. If you are using Ethernet for MODBUS communications, this increases to 124 registers in 400ms per poll.**

- Q: Where can I get the Modbus register map?
 - You can get the latest Modbus register map from LCO Technologies.
- Q: Do you need to put the controller in remote control mode in order to read its registers?
 - A: No, you can read any register in both local and remote modes. You can, however, control speed and pump on/off in remote mode only.
- Q: How do you know the current status of the pump?
 - Connect with the computer or app interface software and select the “System Status” tab (page 25). This tab provides detailed status and diagnostic information.
- Q: If a pump has faulted and stopped for an unknown reason, how can I find out the fault code to troubleshoot if it doesn’t show up as an active fault in the “system status” panel?
 - Depending on which version of the software you are using, the system status tab will display the most recent fault record, under system diagnostics, if available.
 - Alternatively, as the CROSSFIRE controller records the last fault code in the non-volatile memory, it can be accessed through the Terminal Tab. Select the “terminal” tab to send commands to the controller directly. Enter "**showFaultRecord**" and click the send button. The controller will respond with two lines of code:
 - The first being a time and date tag and a 6 digit hex number. The last two digits of the hex number is the fault flag (more information on page 41)
 - 01: Motor stalled due to mechanical jam
 - 02: Motor overload causing over-current or under-voltage
 - 04: Over-current detected by firmware
 - 08: Battery/power supply under-voltage
 - 10: Battery/power supply over-voltage
 - 20: Motor phase A wire is discounted
 - 40: Motor phase B wire is discounted
 - 80: Motor phase C wire is discounted
 - 6X: Motor driver ASIC is damaged (where X is any single digit hex number)
 - The second line of code displays the power supply (battery) voltage and current, and the current at all three phases of the motor at the time of the fault in addition to information on additional advanced features activated.

Example:

Line 1: faultRecord: 20:4:15 13-11-23: 0x646008

Line 2: Vbatt:17.7 Ibatt:0.3 IA:0.3 IB:0.2 IC:0.3 CtrlBlk:0x1 AuxCtrl:0x0

Breakdown of the above Code:

Line 1: faultRecord: Y:M:D H:M:S: Status Code

Line 2: Battery voltage: battery current in Amps: current to each motor phase (A, B & C) in Amps: which automation feature is activated: which I/O control is activated

Troubleshooting:

Controller Fault:

If the *CROSSFIRE* pump is not performing as expected and giving a fault code (or the red fault light is flashing on the controller), follow the steps below in addition to referencing page 41 for a break down of the fault codes. If the problem is MODBUS or communications related, review the setup of the communications (instructions on page 11-12) in addition to steps below.

- 1) Check power supply
 - Ensure the power supply has sufficient current capacity at the maximum load so that supply voltage will not drop below the required 24 VDC
 - For optimal performance, 27-29 VDC is preferred

- 2) Complete a visual check on mechanical components
 - Visually inspect the pump for any mechanic obstructions or signs of chemical damage
 - Look inside the top of the pump, all four green yokes, and around the motor and gearbox
 - Signs of chemical damage usually include chemical precipitate or residue inside the pump or green yokes or around the top motor flange
 - If there is a mechanical obstruction, clear
 - If there is chemical damage, call your supplier for further assistance and replacement parts

- 3) Complete a manual rotation check
 - Confirm the correct number of threads are showing between the brass lock nut and the fluid end body as shown and described on page 9
 - Remove the clear acrylic top cover from the pump
 - Insert an Allen key into the bolt in the center motor shaft and manually spin the motor
 - The motor should spin 360 degrees with no resistance
 - If there is resistance that cannot be rotated past, a fluid end is bottoming out on the plunger
 - In such event, manually spin the fluid end out and off the yoke, one full turn at a time, until you can rotate past the fluid end
 - Then, align the apex of the cam in line with the fluid end of interest
 - Turn the fluid end in (further onto the green yoke) until the plunger bottoms out on the inside of the fluid end
 - Back the fluid end off, just until the arrow on the side of the fluid end body is pointing up (less than one full turn)
 - Tighten brass lock nut to secure position
 - Repeat this process on all fluid ends
 - Re-check and complete a full 360-degree rotation
 - Reference photos of the manual rotation check on page 10



*Video Tutorial of
Manual Rotation*

- 4) Check wiring
 - Ensure wires fall within required specifications as indicated in this manual (beginning on page 7)
 - **Gauge and length are critical**
 - Check that appropriate terminal blocks are used and that no marrettes are used to connect any wires together
 - Ensure appropriate terminal block is used to terminate conductor cables in the junction box as per instructions on page 8
 - Contact supplier to order appropriate terminal block if needed
 - Detach all wires from controller and motor
 - Clean wires with isopropyl alcohol and/or a wire brush
 - Wires may corrode or oxidize overtime and may need cleaning to ensure solid electrical contact
 - Reattach all wires and tighten down connections
 - Replace broken or damaged wires
- 5) Obtain most recent fault code and status report
 - Connect to the LCO CROSSFIRE software as a Technician (psw: **Automatic**) and go to the “terminal” tab
 - Enter "**showFaultRecord**" and click the send button
 - The controller will respond with two lines of code
 - Reference instructions on page 38 for how to read the code
 - Reference instructions on page 41 for a breakdown of the fault code
 - Download system status report
 - Go under “System Setup” tab and download full “system report”
 - The spreadsheet will automatically save to your computer desktop
 - This information will be used for further troubleshooting with your supplier
- 6) Contact supplier for further assistance

Special Condition:

If a specific condition arises where two phases (such as phase A and phase B) read as broken and one phase (such as phase C) reads OK, follow the instructions below. The IC Component on the controller may have been damaged by excessive voltage (not field repairable) or this may indicate poor electrical connection with a phase (field repairable).

- Go to the software terminal tab to diagnose
- Start the pump and read the generated values listed in the terminal tab
- The line of interest will be “**Motor Start: Resistor A**” and “**Motor Start: Resistor B**”
- If either of these values read “**INF**” the IC component is damaged
 - Not field repairable, contact your supplier
- If any of these values exceed 0.5 ohms, but do not read INF, this may indicate a poor electrical connection on a phase wire
 - Follow step 4 in troubleshooting above to check, clean, and re-attach all phase wires
 - Check connections on the controller and in the motor junction box

Fault Codes:

Fault Code	Details	Suggested Troubleshooting
Fault Code: 20 Motor Phase A disconnected	Conductor wire from motor to Phase A has been disconnected	Field Repairable – Follow step 4 in troubleshooting (page 40)
Fault Code: 40 Motor Phase B disconnected	Conductor wire from motor to Phase B has been disconnected	Field Repairable – Follow step 4 in troubleshooting (page 40)
Fault Code: 80 Motor Phase C disconnected	Conductor wire from motor to Phase C has been disconnected	Field Repairable – Follow step 4 in troubleshooting (page 40)
Fault Code: 10 Battery over voltage	Battery voltage is over 32 V	Field Repairable – Follow step 1 in troubleshooting (page 39)
Fault Code: 08 Battery under voltage	Battery voltage is under 18 V	Field Repairable – Follow step 1 in troubleshooting (page 39)
Fault Code: 02 ² or 04 ² Motor Status: Fault detected, overcurrent	Motor has stalled due to: <ul style="list-style-type: none"> – Operating outside design parameters – Insufficient voltage or current – Mechanical obstruction 	Field Repairable – Follow steps 1-5 in troubleshooting (page 39-40) and contact supplier for more assistance if needed
Fault Code: 01 ² Motor Drive Status: Faulted, motor overload, or controller needs repair	Motor has stalled due to: <ul style="list-style-type: none"> – Motor overload due to mechanical obstruction or insufficient power supply <u>or</u> – Controller is damaged and requires repair 	Field Repairable – Follow steps 1-5 in troubleshooting (page 39-40) Not Field Repairable – If the problem persists after following the suggested troubleshooting steps as listed above, the controller may require repair or replacement – Contact supplier for further instructions

² Please note that fault codes 01, 02, and 04 may have similar symptoms and resolutions

Pump and fluid end: Troubleshooting

Issue	Suggested Resolution
Fluid End Leaking – From priming valve	– Tighten handle on bonnet assembly
Fluid End Leaking – From packing	<p>One N' Done Packed Fluid Ends:</p> <ul style="list-style-type: none"> – Complete a manual rotation as per instructions on page 10 <ul style="list-style-type: none"> ○ Confirm the fluid end is installed correctly (not too far on or off) and that the correct number of threads are showing (reference photos on page 9) ○ If the fluid end was installed too far off the top works, the packing lip seal may have been damaged, causing the chemical to leak ○ If the packing is from a brand new installation, by correcting the number of threads and installation position, this may stop the fluid end leak ○ If the pump has been running with this packing for a while, the packing is likely damaged and requires replacement ○ Contact supplier for replacement parts as needed – Visually inspect fluid end, packing and plunger for scoring or damage – Pinch the flow of the discharge side of the fluid end (isolation valve) – Run the pump and monitor the pressure to ensure it remains below the set point of the relief valve – Let the pump run for a few hours – The leak may resolve (if so, un-pinch flow and resume normal operation) – If the leak does not resolve, replace One N' Done packing and plunger as per instructions on page 49 <p>Chevron Vee Packed Fluid Ends:</p> <ul style="list-style-type: none"> – Check to see if the packing gland adjustment nut is loose <ul style="list-style-type: none"> ○ Tighten packing gland adjustment nut until leak stops ○ Ensure packing gland adjustment nut is not over tightened – this may cause damage of the plunger and packing leading to additional leaks ○ If packing gland adjustment nut appears to be bottomed out on the inside of the green yoke, manually rotate the fluid end one-turn in to expose more threads on the yoke interior ○ Complete a manual rotation check to ensure plungers are not bottoming out – Remove fluid end from pump and inspect plunger and packing <ul style="list-style-type: none"> ○ If plunger is scored or damaged, replace both the plunger and packing ○ It is critical to not over tighten the packing gland adjustment nut – Replace packing if leak continues, this may be due to general wear and tear and is a part of regular maintenance <ul style="list-style-type: none"> ○ When replacing packings, ensure each individual Vee ring is inserted one at a time to avoid packing damage

	<ul style="list-style-type: none"> - Talk to your chemical supplier and ensure the packing material is compatible with the chemical; replace packing with a different material if required. <p>Reference page 45 for additional information on chemical degradation and precipitate formation if using a chemical mixture, such as Silicone based corrosion inhibitor and Methanol. This precipitate formation may lead to damaged parts and cause leaks.</p>
<p>Fluid Ends Not Priming</p> <ul style="list-style-type: none"> - Detected by inconsistent or no flow during sight glass gauge test 	<ul style="list-style-type: none"> - When completing a sight glass gauge test, the fluid flow is inconsistent or does not flow at all - This may indicate that your fluid end is not fully primed, or that the ball bearing in the bottom fluid end bushing is sticking <ul style="list-style-type: none"> o Option 1: Connect a hand pump to the threaded vent on the priming valve, open priming valve, and push chemical through the fluid end to completely flood the discharge line. o Option 2: Remove tubing attached to the bottom bushing and unscrew the bushing. Check if the ball bearing is sticking in the O-ring and simply unstick and place back O-ring seat if need be. <p>One N' Done Fluid Ends:</p> <ul style="list-style-type: none"> - Pinch the flow of the discharge side of the fluid end (isolation valve) - Run the pump and monitor the pressure to ensure it remains below the set point of the relief valve - Let the pump run for a few hours - Stop the pump and un-pinch the flow to reset condition - Complete a repeat sight glass gauge test - This exercise may help prime the fluid end
<p>Plunger Bottoming out</p> <p>Four Ways to Detect:</p> <ol style="list-style-type: none"> 1. Manual Fluid End Check 2. The fluid end is not showing correct threads 3. The pump stalls and stops 4. The pump is achieving shorter than expected system autonomy 	<ul style="list-style-type: none"> - Complete a manual rotation check and change the installation of the fluid end and yoke as per the instructions on page 10 - Once the fluid end is installed correctly, repeat the manual rotation check - Check to see if any components were damaged as a result of the plunger bottoming out - Replace damaged parts as needed
<p>Loose Gearbox Collar</p> <ul style="list-style-type: none"> - Detected by: Motor seems to be running, but the pump is not turning. 	<ul style="list-style-type: none"> - A clamp in the gearbox grips the output shaft of the motor (called the gearbox collar) - This collar can be accessed through the two plastic or metal plugs on the side of the gearbox, that are 180 degrees opposite one another - Inside those plugs are Allen head bolts that are used to tighten and loosen the collar - Remove both plugs and reach in with a 4mm Allen key to spin the collar until the Allen bolt is facing straight out through the plug hole - To tighten these bolts, go back and forth between the two sides, tightening in small increments until both bolts are finger tight. It is critical that one bolt is <u>not fully tightened</u> before the other as that will cause misalignment of gearbox and will damage gearbox bearings.

	<ul style="list-style-type: none"> - Once finger tight, tighten until secure (or 80 in lbs if torque wrench is available)
Motor not spinning as expected <ul style="list-style-type: none"> - Detected by: Software motor status reads “running” however motor and pump are not spinning - Potential Fault Code 	<ul style="list-style-type: none"> - Follow the instructions listed on page 39-40
Motor RPM set point not holding with power cycle <ul style="list-style-type: none"> - Detected by: RPM changing from set value - May default to 10 RPM 	<ul style="list-style-type: none"> - Go to www.lcotechnologies.com and download the newest software or mobile app version. A newer software version may identify and fix an existing bug if applicable. - Re-set RPM <ul style="list-style-type: none"> o Stop pump o Use software or app to set required motor RPM o Press Save o Start pump - Ensure System Auto Restart is active when running in Manual Mode <ul style="list-style-type: none"> o Activate in “Automation Tab” by changing “System auto-restart” to On o Press Save - If the problem continues, contact your supplier for more assistance
Worn out top works components <ul style="list-style-type: none"> - Detected by: Slack or movement between the white load block and trunnions, thrust rod and trunnions, or any other component in the top works 	<ul style="list-style-type: none"> - If any movement between components is identified, contact LCO Technologies for assistance <ul style="list-style-type: none"> o Video and photo’s may be requested to help identify which components are damaged - Replacement parts are available for purchase
Pump motor or gearbox out of alignment <ul style="list-style-type: none"> - Detected By: rubbing sound, excessive grinding or noise coming from gearbox or motor 	<ul style="list-style-type: none"> - Remove the pump top works from the gearbox/motor drive system <ul style="list-style-type: none"> o Remove the four M8 bolts connecting the top works to the gearbox (located under the topworks) o Pull the top works up and off the gearbox o Start the pump (gearbox and motor still connected) and observe - Remove the gearbox from the motor <ul style="list-style-type: none"> o Remove the two plugs on either side of the gearbox o Reach inside the gearbox plug hole with a 4mm Allen key and loosen the collar bolt o Repeat on the other side of the gearbox; there are two Allen bolts holding the collar in place o Remove the four M6x40mm bolts holding the gearbox on to the motor o Pull the gearbox up and off the motor o Start the motor and observe - By removing and running the motor separate from the gearbox and top works, this will help identify which component is causing the excessive noise - Consult the LCO factory for further assistance and relay test results

Undetected issue – Controller or Interface is not responding	– Go through all interface troubleshooting steps and the above pump troubleshooting steps – If no resolution, reset and reboot the controller and computer
--	---



Warning: If the pump is injecting a chemical mixture (such as a Silicone based corrosion inhibitor mixed directly with Methanol) this causes degradation of the chemical compound leading the chemical to return to its base elements. This generates mineral precipitates, like Quartz, meaning there will be SiO_2 crystals (sand) in the chemical tank. These mineral precipitates must be filtered out of the chemical mixture before running through the CROSSFIRE pump as the precipitates will cause unusual erosion and damage to the fluid ends. Damage will lead to unreliable performance of the check valves in the fluid ends and will score the plungers and packings causing leaks that can be catastrophic. If your fluid ends are exhibiting these behaviors, please check the chemical mixture and add a 3-micron filter to the chemical lines. Failure to filter this type of chemical mixture will not only lead to extreme pump damage (not covered by warranty) but may reduce the effectiveness of the chemical as originally intended.

LCO Technologies had a third-party lab in Calgary, AB complete an analysis of a common Silicone based corrosion inhibitor mixed with Methanol. They identified this chemical degradation and precipitate formation process described above. Results of this analysis can be shared as requested.

Special Part: LCO Technologies is now supplying a plunger disc with every fluid end. This plunger disc helps prevent chemicals from leaking into the top works if a fluid end is leaking. If you do not have one of these plunger discs on an older pump, please contact LCO Technologies and one will be supplied free of charge. Please ensure the plunger disc remains installed.

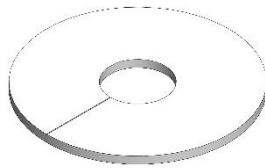

Plunger Disc

Controller Software Connection: Troubleshooting

Connection Errors

When attempting to connect to the controller, a connection error may occur. The following table lists common errors, and solutions:

Error Message	Description & Solution
Error: Password must not be blank	<p>In order to successfully log in to the controller, the password must be entered.</p> <p>Possible solutions:</p> <ol style="list-style-type: none"> 1) Retry connection and enter password (password is case sensitive)
Could not connect to controller: No response	<p>When attempting to connect to the controller, the software received no response.</p> <p>Possible solutions:</p> <ol style="list-style-type: none"> 1) Ensure that the serial cable or Bluetooth serial adapter used to connect to the controller is inserted securely into both the computer and the <i>CROSSFIRE</i> controller. 2) If you are connecting using a Bluetooth serial adapter, you may be out of signal range or near a radio interference source. Move closer to the controller. 3) Ensure the correct COM port is listed (see: Troubleshooting – COM Port Issues – page 46). 4) Ensure the <i>CROSSFIRE</i> controller is powered on
Could not connect to controller: Unknown response	<p>When attempting to connect to the controller, the software received an unrecognized response.</p> <p>Possible solutions:</p> <ol style="list-style-type: none"> 1) Ensure that the serial cable or Bluetooth serial adapter used to connect to the controller is inserted securely into both the computer and the <i>CROSSFIRE</i> controller. 2) Ensure the correct COM port is listed (see: Troubleshooting – COM Port Issues – page 46). 3) Ensure the BAUD rate listed is correct (default – 115200) 4) If the problem persists, try connecting with an alternate RS232 cable or Bluetooth serial dongle.

<p>Could not connect to controller:</p> <p>Incorrect password</p>	<p>When attempting to connect to the controller, the wrong password was provided.</p> <p>Possible solutions:</p> <ol style="list-style-type: none"> 1) Retry connection and ensure you have the correct password (note: the password is case sensitive) 2) Ensure you are connecting under the right user (operator or technician) that corresponds to the correct password
<p>Disconnected:</p> <p>Login session with controller expired</p>	<p>For security reasons, the login session with the controller is automatically terminated after one hour. This can be configured to an alternate logout time period if requested.</p> <p>Possible solutions:</p> <ol style="list-style-type: none"> 1) Reconnect and log back into the controller.
<p>Disconnected:</p> <p>Communication with controller lost</p>	<p>The software lost connection to the <i>CROSSFIRE</i> controller for unknown reasons.</p> <p>Possible solutions:</p> <ol style="list-style-type: none"> 1) Check that the RS232 serial cable or Bluetooth serial adapter has not come loose either from the computer or from the <i>CROSSFIRE</i> controller. 2) If connecting using a Bluetooth serial adapter, the connection may have been lost due to signal interference or from moving too far away from the <i>CROSSFIRE</i> controller. Move closer to the controller and away from any radio sources. 3) The <i>CROSSFIRE</i> controller may have lost power. Check that the controller is powered on and that the system voltage level is adequate.

COM Port Issues

If the software continues to have trouble connecting to the *CROSSFIRE* controller, it may be caused by the serial link to the controller.

- 1) Select a different COM port in the connection window
- 2) Close all other software that could be using the serial connection
- 3) Close and reopen the *CROSSFIRE* software
- 4) Restart the computer

Other Miscellaneous Issues

If the software is having trouble saving configurations, or showing other miscellaneous problems or inconsistencies, please ensure you have the most up-to-date software version by visiting www.lcotechnologies.com/resources.html and downloading the software (zip file password: crossfire2017). The top menu bar within the software will indicate the version number for your reference. If these problems persist after downloading the most recent software version, please contact your supplier.

CROSSFIRE Maintenance

The *CROSSFIRE* requires minimal maintenance, however, below is a list of recommended maintenance practices. The recommended time frame is estimated and may need to be adjusted based on usage.





Warning: Exercise standard lockout procedures for electrical equipment prior to servicing any component on the *CROSSFIRE*. Please follow all appropriate safety protocols when handling the fluid ends as they may have been in contact with dangerous chemicals. Please reference MSDS sheets and your company safety protocols prior to disassembling the fluid ends.

Maintenance Required	Recommended Time Frame
Inspect and replace fluid end soft goods	<ul style="list-style-type: none"> – Inspect fluid ends Semi-Annually – Replace when a leak or wear and tear is detected – Chevron vee packings will likely need replacement semi-annually, where as One N' Done packings may need replacement annually (or longer, depending on application) – If the packing requires replacement, replace the plunger at the same time 
Clean and lubricate plungers	<ul style="list-style-type: none"> – Monthly – Wipe and clean plungers with cloth – If using a chevron vee packing, re-lubricate the plunger OD with Red N Tacky lubricant – Do not add lubrication to the plunger if using a One N' Done packing (the plunger must remain dry)
Clean & lubricate thrust rod, load block and trunnions	<ul style="list-style-type: none"> – Monthly – Wipe and clean out old dirty grease – Lubricate with Red N Tacky brand lubricant – Lubricate all four sides of load block in addition to top
Clean yokes	<ul style="list-style-type: none"> – Monthly – Clean out any debris or chemical particulate – Pay extra attention to the base of the yoke – If the yoke port is blocked, any chemical leaks will sit in the yoke and may leak into top works, gearbox, and motor causing irreparable damage
Clean and reattach wiring	<ul style="list-style-type: none"> – Annually – Inspect all wires – Detach wires and clean with a wire brush or isopropyl alcohol – Reattach wires and tighten appropriately to ensure solid electrical contact – Replace damaged wires as needed
Complete a manual rotation check	<ul style="list-style-type: none"> – Anytime pump or fluid ends are being serviced or Semi-Annually – Complete a manual rotation check as described on page 10 to ensure pump is properly set up
Upgrade software and firmware if available	<ul style="list-style-type: none"> – Annually or as needed – Go to the LCO Technologies website and download the newest version of the desktop or app software – If controller has bootloader technology for site firmware upgrade capability (firmware <u>version V38 or later</u>), follow the instructions on page 52 and upgrade the firmware of the controller for the most up to date version

Maintenance Instructions:

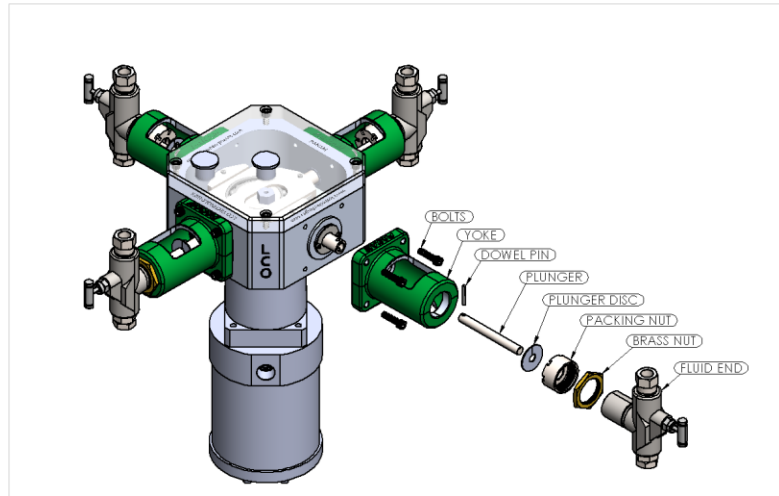
Trunnions

**Replacement of
LCO One N' Done Packing and Plunger:**

- Step 1: Ensure the motor is powered off and the priming valve is completely closed
- Disconnect all fluid lines and isolate chemicals
- Step 2: Remove the four hex cap bolts on the fluid end yoke
- Step 3: Slide the fluid end and yoke off the plunger
- Step 4: Unscrew the packing gland adjustment nut and yoke
- Step 5: Remove the top and bottom bushings off the fluid end
- Step 6: Replace the O-rings in the bottom bushing and inside seat
- Item #4, #10, and #11 as shown in the labelled technical drawing on page 54
- Step 7: Remove old packing and discard
- Step 8: Install new One N' Done packing
- Lube the OD of the spring lip and the o-ring just up from it, both of which are on the outside of the One N' Done cartridge packing
 - o Recommended lube: Red N' Tacky, rice grain sized amount
 - **Do NOT lube the ID of the cartridge packing.** It is essential that the ID of the packing and the plunger remain dry! 
 - Press the packing into the fluid end chamber (spring side first)
- Step 9: Remove old plunger and install new plunger
- Tap out the dowel pin holding the old plunger in place with a hammer and a 1/8" metal punch - discard old plunger
 - Insert new plunger and tap dowel pin in 
 - **Do NOT lube the plunger**
- Step 10: Attach yoke, new Delrin follower and packing gland adjustment nut
- Thread yoke back onto fluid end
 - Insert new Delrin follower on top of the packing
 - Screw down the packing gland adjustment nut until bottomed out (just finger tight, no torque required)

Ensure the correct number of threads are showing between yoke and the brass lock nut/lock ring. For clarification, see page 9. 

- Step 11: Slide fluid end/yoke on plunger
- Step 12: Screw 4 hex cap bolts back through the yoke into the pump

Step 13: Complete a manual rotation fluid end check (instructions on page 10)

Note: A complete instruction guide with pictures is provided with the purchase of a replacement One N' Done packing. Please reference this document for more information and detailed instructions.

Replacement of Chevron Vee Packing and Plunger:

Step 1: Ensure the motor is powered off and the priming valve is completely closed

- Disconnect all fluid lines and isolate chemicals

Step 2: Remove the four hex cap bolts on the fluid end yoke

Step 3: Slide the fluid end and yoke off the plunger

Step 4: Unscrew the packing gland adjustment nut and yoke

Step 5: Remove the top and bottom bushings off the fluid end

Step 6: Replace the O-rings in the bottom bushing and inside seat

- Item #4, #10, and #11 as shown in the labelled technical drawing on page 55

Step 7: Remove old packing and replace with a new packing

- Remove the packing gland and old packing
- Add a rice grain sized amount of Red N Tacky lubrication in the fluid end packing cavity
- Put a new packing in and ensure the Vee ring “point” is pointing outwards
- Install each vee ring one ring at a time
- Insert the packing gland on top of the new packing

Step 8: Screw the yoke and bushing back onto the fluid end

Ensure the correct number of threads are showing between yoke and the brass lock nut/lock ring. For clarification, see page 9.



Step 9: Screw the packing gland adjustment nut back onto the fluid end

- Do not overtighten the packing gland adjustment nut, it should be snug

Step 10: Remove old plunger and install new plunger

- Tap out the dowel pin holding the old plunger in place with a hammer and a 1/8” metal punch
- Discard old plunger
- Insert new plunger and tap dowel pin in
- Apply a rice grain sized amount of Red N Tacky lubrication onto the plunger

Step 11: Slide the fluid end/Yoke combo back onto the plunger

Step 12: Screw 4 hex cap bolts back through the yoke into the pump

Step 13: Complete a manual rotation fluid end check (instructions on page 10)

Inspection

In addition to regular maintenance, inspect all pump components on a semi-annual basis. Replace or repair parts as necessary.

Recommended Inspection practice:

- Check for any signs of corrosion or pitting with in the fluid ends or on the pump
 - Check with supplier to ensure you have appropriate metallurgy and soft goods to prevent further damage. Replace any damaged components.
- Inspect all seals and soft goods for damage or wear and tear
 - Replace seals and soft goods if they appear damaged or leaks occur that cannot be corrected
- Inspect the interior cavity of the fluid end for any pitting or damage
 - Replace the fluid end and check with suppliers for chemical compatibility
- Inspect all aspects of the pump for any damage
 - Special attention should be paid to all cables and connectors for signs of damage. If there is any damage to these cables or connectors, **replace immediately.**

Controller Firmware Upgrade:

Note: Only applicable for controllers with **V38 firmware or later**. Controller must be powered on to complete this upgrade.

Download Required Software and Files

- Go to the LCO Technologies website and download two files from the “resources” tab onto your computer (<https://lco technologies.com/resources.html>)
- File 1: “CROSSFIRE firmware update tool” – password “**crossfire2023**”
- File 2: “CROSSFIRE latest firmware” file – save to computer

Step 1: Connect your computer to the controller with a RS232 to USB cable

- This firmware update cannot be done over Bluetooth connection, hardware required
- Connect serial port and ensure COM port is selected properly

Step 2: Open the firmware update tool and “Select File for Upload”

- Locate the file that was just downloaded and saved from the LCO website

Step 3: Get into bootloader mode

- Password: “Automatio”
- Click on “Login to Target” – the Terminal section above will load and confirm successful login
- Click on “Jump to Bootloader” – you are ready to begin the upload

Step 4: Upload Image

- Click on “Start Upload”
- The firmware should now be uploading
- The process takes a few minutes (visual progress bar in software)

Finalize Upgrade

- When complete, locate the section called “Other Tools – Send CMD to Target” (top right hand corner)
- Copy the first line and hit send, and follow suit with the other two
- The first is to enable a feature, the second is to confirm everything has uploaded successfully, and the third is to ensure motor is reading from controller accurately

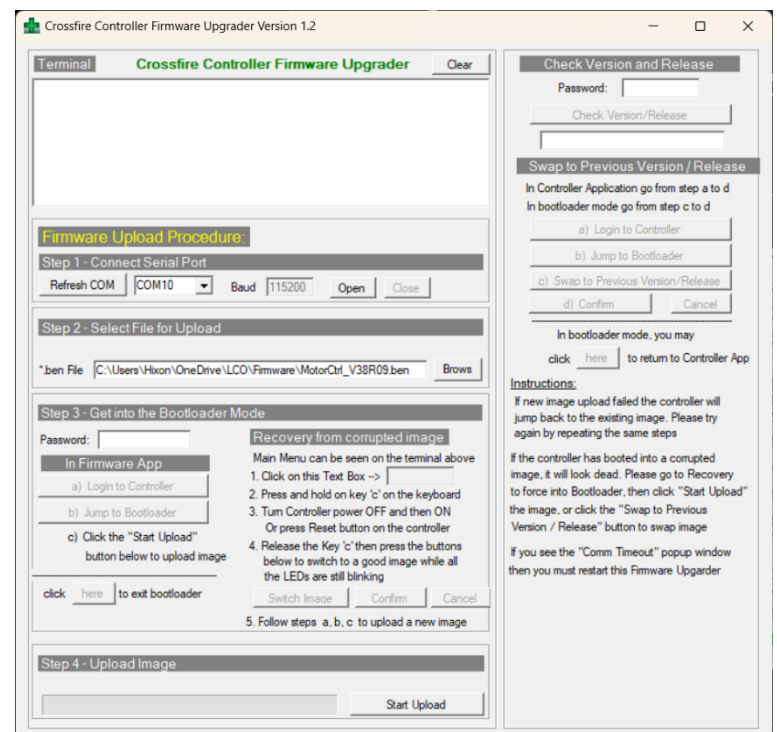

Assembled CROSSFIRE Chemical Injection Pump:

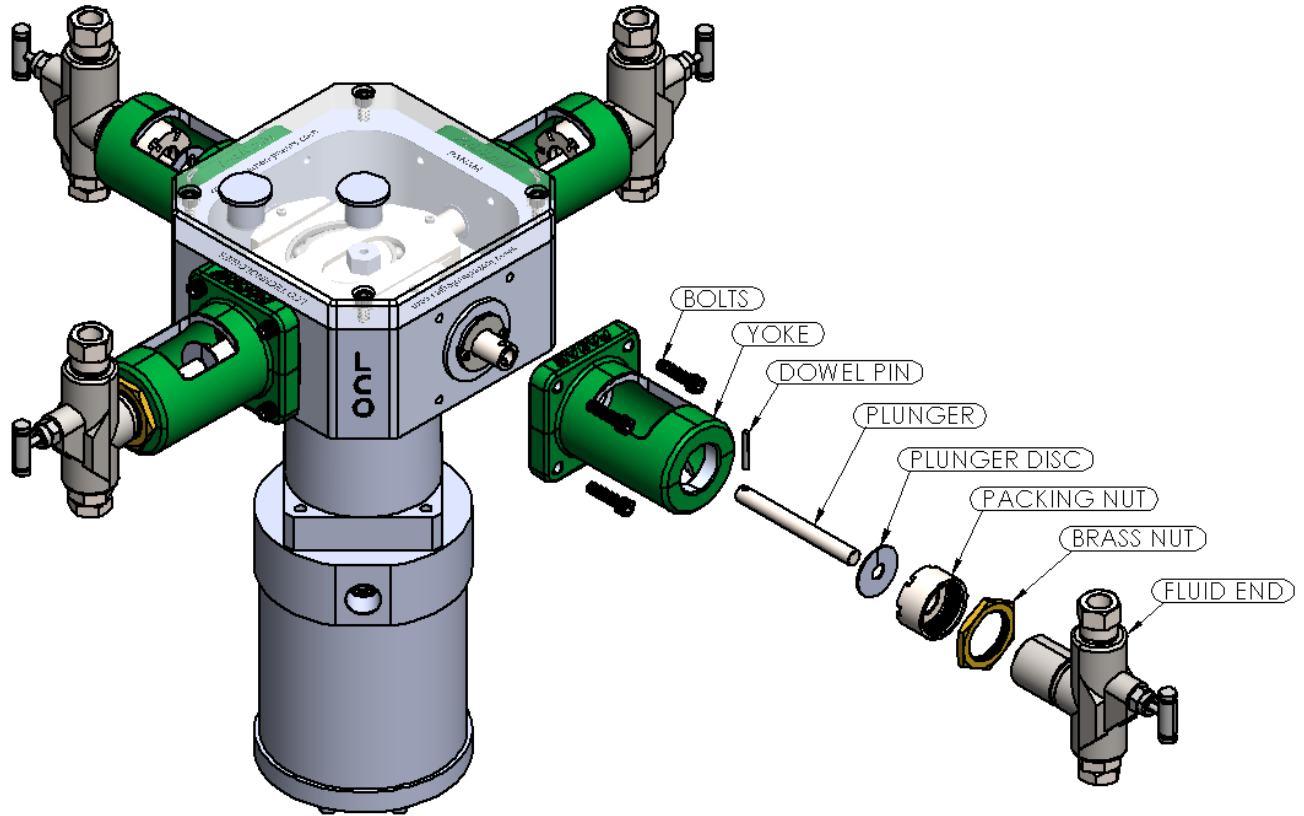

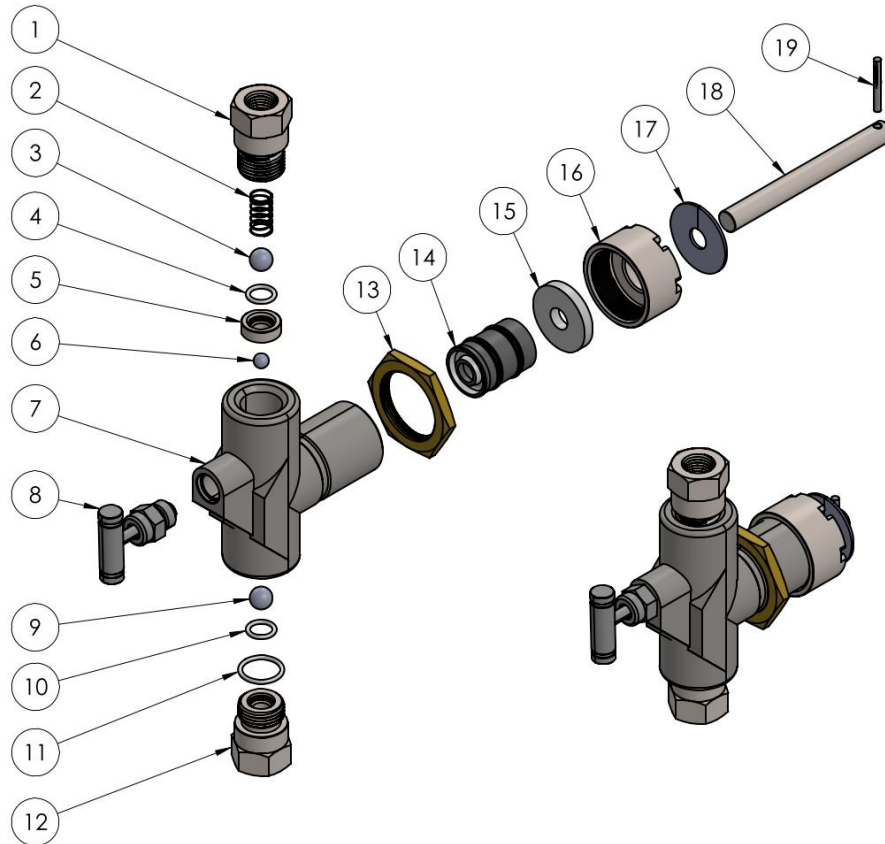
One N' Done Packing Fluid End (PFE-SS-00-1ND-XF): Technical Drawing

Item	Part Description	Material
1	Top Bushing	316 SS
2	Spring	316 SS
3	3/8" Ball Bearing	316 SS
4	Small O-ring	XF1 – LCO Proprietary Blend XF2 – High Temp. FFKM
5	Inside Seat	17-4 PH
6	1/4" Ball Bearing	316 SS
7	Panam Fluid End – Body	316 SS
8	Bonnet Assembly	Viton Packed
9	3/8" Ball Bearing	316 SS
10	Small O-ring	XF1 – LCO Proprietary Blend XF2 – High Temp. FFKM
11	Large O-ring	XF1 – LCO Proprietary Blend XF2 – High Temp. FFKM
12	Bottom Bushing	316 SS
13	Brass Lock Nut/ Lock Ring	Brass
14	One N' Done Cartridge Packing	XF1 – LCO Proprietary Blend XF2 – High Temp. FFKM
15	One N' Done Packing Follower	Delrin
16	Packing Gland Adjustment Nut	316 SS
17	Plunger Disc	Delrin
18	Plunger	17-4 PH - Nitrided
19	Half groove Dowel Pin	Zinc plated carbon steel

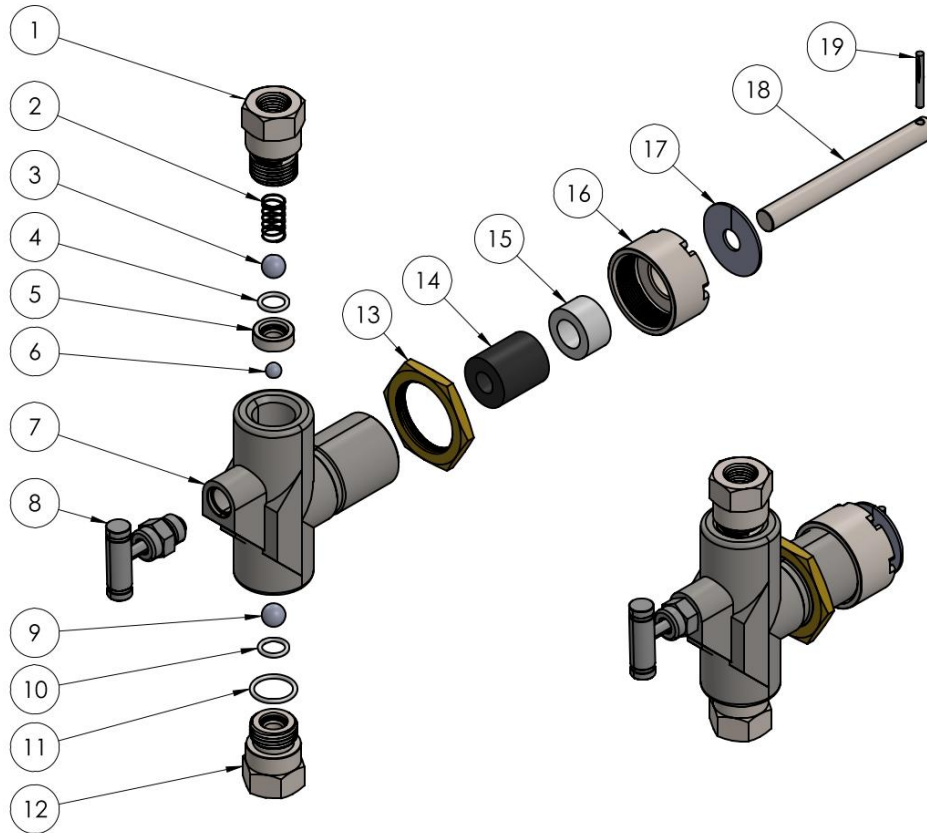
Chevron Vee Packing Fluid End (PFE-SS-00-X): Technical Drawing

Item	Part Description	Material
1	Top Bushing	316 SS
2	Spring	316 SS
3	3/8" Ball Bearing	316 SS
4	Small O-ring	Various materials available such as: Buna, Teflon, Viton etc.
5	Inside Seat	17-4 PH
6	1/4" Ball Bearing	316 SS
7	Panam Fluid End – Body	316 SS
8	Bonnet Assembly	Viton Packed
9	3/8" Ball Bearing	316 SS
10	Small O-ring	Various materials available such as: Buna, Teflon, Viton etc.
11	Large O-ring	Various materials available such as: Buna, Teflon, Viton etc.
12	Bottom Bushing	316 SS
13	Brass Lock Nut	Brass
14	Packing	Various materials available such as: Buna, Zebra (Buna/Teflon), Teflon, Viton etc.
15	Packing Gland	Delrin
16	Packing Gland Adjustment Nut	316 SS
17	Plunger Disc	Delrin
18	Plunger	17-4 PH – Nitrided
19	Half Groove Dowel Pin	Zinc plated carbon steel

CROSSFIRE Return and Repairs

Note: When repairing a unit or disassembling to be sent back for replacement, please take every step to ensure the safety of people and environment. Follow all protocols as set out by your company and ensure all employees are properly trained prior to disassembly.

Repairs

- Fluid Ends
 - Fluid ends can be fully repaired and swapped out in the field. Regular maintenance with semi-annual inspection of soft goods (packings and O-rings) is recommended.
 - Fluid end repair kits are available for purchase from your supplier

Replacement

- Motor/Gearbox
 - If the motor or gearbox stops working out in the field:
 - The unit may be repairable by LCO Technologies **or**
 - This will constitute a replacement
- Controller
 - If the controller stops working or is not functioning as expected and is not due to a troubleshooting or installation error:
 - The controller may need a firmware and/or hardware upgrade **or**
 - The controller may be repairable by LCO Technologies **or**
 - The controller may need a complete replacement

Return Procedure

- Please follow your suppliers return protocols to ensure that all components are properly cleaned prior to sending gear back



LCO Technologies, the manufacturer, is not responsible for improper product installation or use. In the event of a discrepancy, please refer to our standard terms and conditions.

LCO Technologies

#115, 1829 54 Street SE

Calgary, AB T2B 1N5

Info@lcotechnologies.com

www.lcotechnologies.com